



Operating Manual

KÖCO Compact Stud Welding Equipment



KÖCO Stud Welding Guns

CLASSIC

SK 14 from no. 10000

SK 14-ISO from no. 17200

SK 14 short

SK 15

K 22

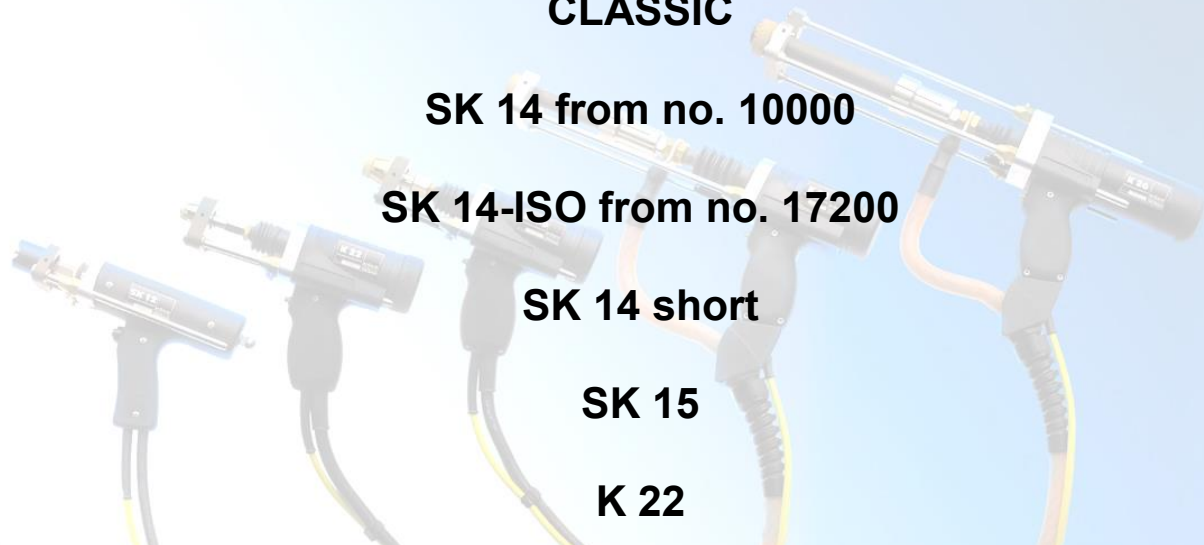

This operating manual has the part-no. 399-0501-000. It is a translation of the original document.



UKCA-Declaration of Conformity

This declaration of conformity is issued under the sole responsibility of the

manufacturer: Köster & Co. GmbH
Spreeler Weg 32
58256 Ennepetal
Germany, North Rhine Westphalia

Product Type: **stud welder**
Product Model: **905i**
Serial Number: 761069 -

The object of the declaration described above is in conformity with the essential requirements and other relevant requirements of the:

Supply of Machinery (Safety) Regulations 2008 (S.I. 2008/1597)

Electromagnetic Compatibility Regulations 2016 (S.I. 2016/1091)

Restriction of the Use of Certain Hazardous Substances in Electrical and Electronic Equipment Regulations 2012 (S.I. 2012/3032)

Standards applied:

EN 60204-1 „Safety of machinery - Electrical equipment of machines - Part 1: General requirements“
EN IEC 60974-1 „Arc welding equipment - Part 1: Welding power sources“
EN 60974-10 „Arc welding equipment - Part 10: Electromagnetic compatibility (EMC)“

This declaration of conformity loses its validity if the product is converted or modified without consent.

Authorized person for compiling the relevant technical documentation

Köster & Co. GmbH
Development, Mr. Enno Putzer
Spreeler Weg 32
58256 Ennepetal
Germany, North Rhine Westphalia

Signed for and on behalf of: Köster & Co. GmbH, 58256 Ennepetal

Ennepetal, 01.01.2023 Dr. Torben Schmitz, Managing Director



Original-EG-Konformitätserklärung

Die alleinige Verantwortung für die Ausstellung dieser Konformitätserklärung trägt der

Hersteller: Köster & Co. GmbH
Spreeler Weg 32
D-58256 Ennepetal

Bezeichnung der Maschine: Bolzenschweißgerät
Serien- / Typenbezeichnung: **905i**
Seriennummer: 761069 -

Der oben beschriebene Gegenstand der Erklärung erfüllt die einschlägigen Harmonisierungsrechtsvorschriften der Union:

2006/42/EG	Maschinenrichtlinie
2014/30/EU	Elektromagnetische Verträglichkeit (EMV-Richtlinie)
2011/65/EU	Beschränkung der Verwendung bestimmter gefährlicher Stoffe (RoHS-Richtlinie)

Harmonisierte Normen, die zugrunde gelegt wurden:

EN 60 204-1 „Elektrische Ausrüstung von Maschinen“
EN 60 974-1 „Sicherheitsanforderungen für Einrichtungen zum Lichtbogenschweißen“
EN 60 974-10 „Elektromagnetische Verträglichkeit (EMV), Produktnorm für Lichtbogenschweißeinrichtungen“

Sonstige technische Spezifikationen, die angewendet wurden:
DGUV Vorschrift 1

Diese Konformitätserklärung verliert ihre Gültigkeit, wenn das Produkt ohne Zustimmung umgebaut oder verändert wird.

Bevollmächtigter für die Zusammenstellung der relevanten technischen Unterlagen

Köster & Co. GmbH
Entwicklung, Hr. Enno Putzer
Spreeler Weg 32
D-58256 Ennepetal

Unterzeichnet für und im Namen von: Köster & Co. GmbH, 58256 Ennepetal

Ennepetal, 01.01.2023 Dr. Torben Schmitz, Geschäftsführer



Table of Contents

Operating Manual KOCO Compact Stud Welding Equipment 905i	1
KOCO Stud Welding Guns CLASSIC SK 14 from no. 10000 SK 14-ISO from no. 17200 SK 14 short SK 15 K 22	1
UKCA-Declaration of Conformity	2
Original-EG-Konformitätserklärung	3
Table of Contents	4
1 Introduction	6
1.1 Information for the User	6
1.2 Safety Instructions	6
1.2.1 Personal Safety	6
1.2.2 Operational Safety of the Equipment	7
1.2.3 Safety When Working	7
2 Drawn Arc Stud Welding	9
2.1 Technical Data on Power Source 905i	10
2.2 The Power Source	11
2.3 The Welding Gun	11
2.4 Technical Data on Stud Welding Guns CLASSIC	12
2.5 Setting Guidelines for welding with ceramic ferrule or shielding gas	13
2.6 Setting guidelines for short cycle stud welding without weld pool protection or with shielding gas	14
2.7 Material requirements	14
3 Working with the stud welding equipment	15
3.1 Requirements before starting-up	15
3.2 Starting-up of the welding gun	15
3.3 Starting-up of the Power Source	18
3.4 Operation of the power source	18
3.4.1 Main menu	18
3.4.2 Language selection	18
3.4.3 Counter functions	19
3.5 Welding	19
3.6 Weld Testing	20
3.7 Maintenance of the Welding Power Source	22
3.8 Maintenance of the Welding Gun	22
3.9 Maintenance of Welding and Control Cables	22
3.10 Calibration	23
3.11 Shutting-Down	23



3.12	Waste Disposal	23
4	Remedies for Malfunctions	24
4.2	Other Malfunctions	24
5	Pictures of the Power Source 905i	26
6	Spare Parts for Welding Power Source 905i	30
7	Pictures of Stud Welding Guns CLASSIC	31
8	Spare Parts for Stud Welding Guns CLASSIC	38
8.1	Spare parts list gun series SK 14 and SK 15	38
8.2	Spare parts list guns K 22, K 22-D, K 24, K 26	39
9	Pictures of Cables	42
10	Cable Spare Part List	43
11	Schematic Circuit Diagram	44
12	Accessories	45
12.1	Gun accessories for stud welding guns K 22 to K 26	45
12.2	Gun accessories for Gun series SK 14 and SK 15	59
13	Literature	63



1 Introduction

Dear User,

With the KÖCO Stud Welding Equipment 905i you have purchased an appliance of superior quality. It has been constructed according to latest technical principles and complies with all technical regulations and requirements in force at the time of delivery. To achieve trouble-free operation at all times we recommend that you observe the following instructions:

- Before starting-up carefully read through the complete manual and make sure that anyone on your staff handling or operating the appliance has also read and understood the instructions.
- The safety instructions must be followed at all times.
- Store this manual in a safe place, with easy access for anyone operating the appliance.
- The appliance may only be operated by sufficiently qualified personnel.
- Secure the machine against use by unauthorized persons.
- Have a trained electrician inspect the mains connection for correct fusing and earthing.
- If any malfunctions occur which you cannot remedy yourself, call our after-sales service.
- In case of accidents call for proper medical help, and if necessary, notify accident insurers and/or local trade supervision authorities.

1.1 Information for the User

The manual for your KÖCO stud welding equipment 905i and the KÖCO stud welding guns CLASSIC contains any necessary instruction to the equipment, for safe carrying-out of stud welding operations and their assessment. All information supplied is given to the best of our knowledge, but without accepting any liability on our part. In particular, we cannot accept any responsibility for welding suitability of workpieces, nor for the suitability of the stud welding process for certain applications. In all of these cases responsibility for welding results rests with the user.

We shall be glad to assist you with any questions you may have concerning particular applications or remedies for malfunctions. Any suggestions on your part towards improving this operating manual will also be welcome.

1.2 Safety Instructions

The KÖCO stud welding equipment 905i and the KÖCO stud welding gun CLASSIC is designed for use in drawn-arc stud welding only. It must not be used for any other purpose, with the exception of manual electrode welding, and then only if the appliance is equipped for this purpose. In particular, welding under water is strictly prohibited, nor is it permissible under any circumstances to use the appliance for thawing up frozen water pipes.

1.2.1 Personal Safety

KÖCO stud welding equipment 905i and the KÖCO stud welding guns CLASSIC are approved for welding under increased electrically hazardous conditions, according to DIN EN 60974-1. For his own safety, the operator must wear protective clothing during welding, which includes the following:

- Dry, insulating shoes
- Non-flammable, dry (and free from inflammable matter), close-fitting working clothes (leather apron)
- Leather gloves
- Safety goggles with an adequate degree of protection
- A special helmet with neck protection while engaged in overhead welding



-
- No metallic jewellery (rings, chains, etc.) or watches may be worn during welding.
 - During the welding process, persons wearing heart pace-makers must be kept at a safe distance from the appliance and the welding cables, because the strong magnetic fields could endanger their lives.
 - In addition to the above, all normal accident prevention regulations must be observed.

1.2.2 Operational Safety of the Equipment

- **For the mains connection only a suitable mains plug or a fixed mains connection may be used.** The installation of a fixed mains connection (including fitting of the mains plug) may only be carried out by a trained electrician.
- **All cable insulation must be in perfect condition.** Cables with defective insulation must be replaced immediately. Welding cables may carry high currents. At points subject to bending, for example where the cable enters the handle of the welding gun, there is always a risk of the cross-section being gradually reduced due to breakage of individual wires. When subjected to a high pulsed current, a cable thus weakened may suddenly arc over and burn out. This means a risk of burns to the operator, and of inflammable objects nearby being ignited.
- **All parts of the housing must be firmly attached.** Operation with an open housing is not permissible, because then there is no protection against touching live parts, and effective ventilation is also prevented.
- **The insulating wheels (casters) must be in perfect condition.** If these casters are removed in order to install the equipment in a fixed position, alternative insulation must be provided between the workpiece and the housing. If an electric connection between the workpiece and the housing exists during welding, this may, in case of malfunction, destroy the protective earth-line of the equipment.
- **The interior of the appliance must be kept clean.** Especially when working in dusty surroundings, dust will collect on parts of the equipment. Therefore, the housing should be opened at regular intervals (only after first disconnecting the mains plug) and the dust blown out. This is vital in the case of metallic dust, because it can lead to short circuits and thus cause damage to the components. Do not aim the jet of air at any pc boards, but remove the dust from these with a vacuum cleaner.
- **Sufficient cooling.** The cooling air is taken in at the bottom and blown out at the rear side. Provide sufficient facilities of air ventilation. Do not cover the ventilation openings.
- **The welding gun must be in perfect condition.** All connections in the welding circuit must be tight. Make sure that the chuck is firmly seated on the adapter screw and that the stud is firmly seated in the chuck. Otherwise contact scorching may result. Do not operate the gun without rear cap. For adequate protection against welding splashes and smoke the bellows protection must always seal perfectly.
- **Electrical safety:** Before opening the appliance always disconnect it from power supply by pulling out the mains plug, making sure that it is not possible to switch it on unintentionally. Prevent moisture or foreign substances from entering the power source. If this happens, the appliance must immediately be disconnected from the mains power supply. The appliance should also be inspected by a qualified specialist at regular intervals, especially following any malfunction. Make sure that all markings remain visible!

1.2.3 Safety When Working

- Do not operate the equipment in areas of fire or explosion danger. Remove all inflammable objects from the surroundings!
- Keep in mind that welding splashes are likely to ignite inflammable objects, for example cleaning rags soaked with oil, grease or solvent, or packing materials, even at several metres' distance!
- In case of doubt check with the security officer in charge and obtain his release before commencing work!
- Make sure that the operating site has sufficient ventilation!
- Do not weld without air extraction on any workpieces which may release substances dangerous to health, such as coating materials, zinc, nickel, chromium or cadmium!



-
- Do not carry out welding on hollow objects which contain, or have contained, inflammable liquids or gases, or which are under pressure, or inside which a dangerous level of pressure can be generated by welding heat!
 - The heat generated by welding may lead to the release of gases or vapours which are dangerous to health or even explosive. Specialized knowledge is required for this kind of work. Do not carry out such operations unless you possess the necessary knowledge!
 - Keep at a safe distance from any equipment which might be affected by magnetic fields, such as EDP installations (computers), cards with magnetic strips, or timepieces (wrist-watches)
 - Do not weld on the same workpiece (welding potential) simultaneously with other types of welding machines, especially those working with different poles or frequency (alternating current), or welding equipment with high voltage ignition, because this can adversely affect or damage the control unit of the stud welding appliance.
 - Ensure that a flawless safe welding circuit is generated. The earthing cables should be firmly clamped onto the workpiece. If this is not possible or not desirable, make sure that there are no parts in contact with the welding circuit which can be damaged or destroyed by the welding current, such as crane hooks, rolling bearings, clamps with layers of partly insulating material, screws or rivets. Especially dangerous is the destruction of protective conductors in other electric appliances when they come into contact with the welding current.
 - Whenever the appliance must be placed on sloping ground, secure it against tipping over or rolling downhill.
 - For transporting the equipment, use only the parts specially provided for this purpose. The handles of the appliance are not designed for transporting it by crane.
 - While setting up or adjusting the welding gun, unintentional triggering of the gun pushbutton must be avoided, either by turning off the power switch or by disconnecting the control cable plug from the flange socket on the power source.

2 Drawn Arc Stud Welding

Drawn-arc stud welding is used for the welding of metallic parts, generally of cylindrical shape, onto metallic workpieces. For this purpose, a DC power source and a mobile device, the welding gun, are required. Depending on the type of welding-pool protection and welding time range used, the appropriate process may be stud welding with a ceramic ferrule, stud welding with with shielding gas, or short-cycle stud welding, either with or without shielding gas.

The welding procedure is illustrated below:

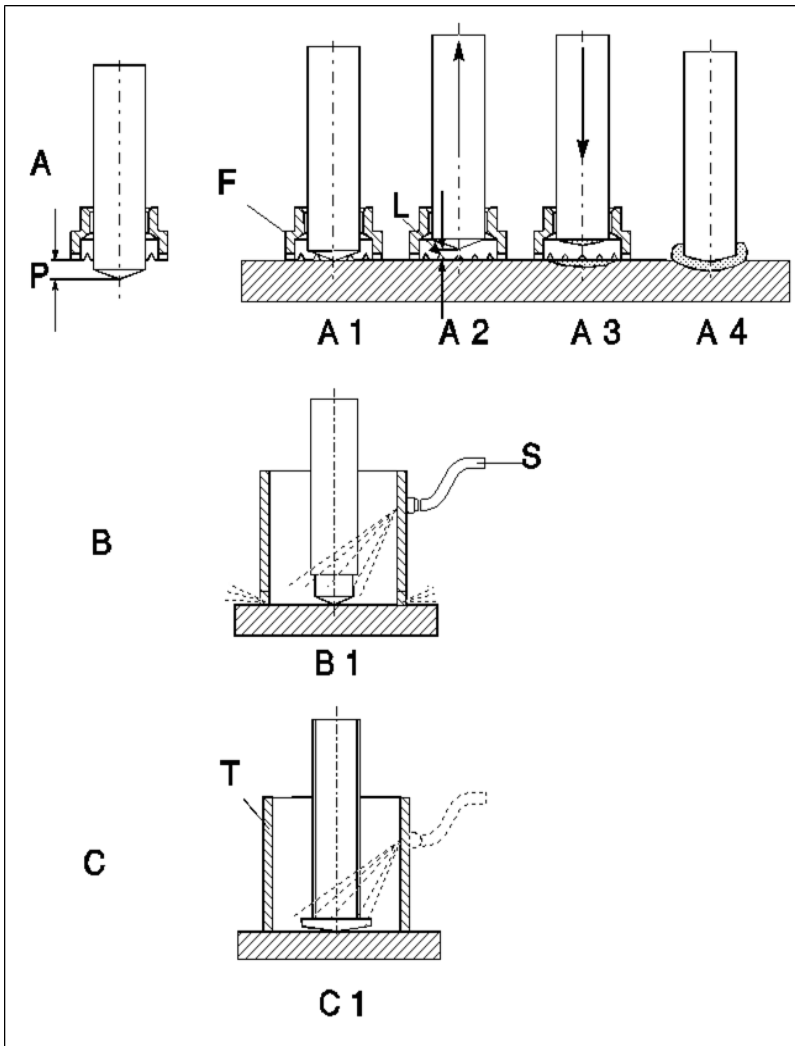

Explanation:

A: Stud welding with ceramic ferrule

F: Ceramic ferrule

P: Protrusion

L: Lift

A 1: The stud contacts the workpiece.

A 2: The stud is lifted off under current flow and thus the arc ignited.

A 3: The drawn arc melts the tip of the stud and the portion of the workpiece directly beneath it. At the end of welding time the stud is pressed (plunged) into the molten part of the workpiece.

A 4: The melt solidifies, resulting in a firm cross-sectional weld. The ceramic ferrule is then removed.

B: Stud welding with shielding gas. (B 1 equivalent to A 1)

S: Shielding gas supply

C: Short-cycle stud welding with or without shielding gas (C 1 equivalent to A 1)

T: Supporting tube

Figure 1: Drawn-arc stud welding procedure



2.1 Technical Data on Power Source 905i

Technical data	905i
Stud welding with ceramic ferrule weldable stud range Ø (mm)	3 - 12
Short-cycle stud welding weldable stud range Ø (mm)	3 - 8
Stud welding with shielding gas weldable stud range Ø (mm)	3 - 10
Stepless current adjustment range, (A)	100 - 800
Stepless time adjustment range (ms)	1 - 800
Number of storage locations for current, time and gas preflow time	20
Max. weld rate in studs/min. for ... stud Ø (mm)	4/12 9/10
Self diagnosis: Overheating	●
Short circuit control cable	●
Mains phase missing	●
Micro processor control	●
Constant current control	●
Repeat cycle lock	●
Input voltage, three-phase 50/60 Hz (V)	400
Mains plug 400 V (A)	32
Mains cable 4-pole, 400 V (m/mm ²)	5/4
Max. extension cable permissible to mains connection (cross section identical to mains extension cable) ²⁾	25
Time-lag fuse for 400 V (A)	20
Input performance at ...% ED (kVA)	3/45 7,5/28 100/7,5
Max. welding cable length under given current (A) with given cross section ²⁾	600 / 25 m at 70 mm ²
Input voltage tolerance (%)	-15/+6
Class of protection	IP 23
Cooling	F
Steel housing, powder coated	●
Housing dimensions L x W x H (mm)	410 x 220 x 250
Handle	1
Weight (abt. kg)	18
Shielding gas equipment	●
Gas preflow time (ms)	1 - 2000

● = Standard

Operating under increased electrical hazard permissible, CE-labelling according to EN 60974-1

2) The permissible max. lengths of extensions to mains and welding cables may be extended for welding under lower currents than the current given. In case of low current input it may not be possible to use maximum lengths for both mains and welding cable extensions.

2.2 The Power Source

The power source consists of a primary chopped inverter with constant current control, a choke connected in series, and an electronic control. The machine is laid out for a mains voltage of 400 V (3-phase). Operation with other voltages is also possible by interposing a transformer.

Nominal output of the equipment can still be reached with an undervoltage of up to minus 10%. However, depending on circumstances, it may become necessary to shorten the extension cables, to prevent exceeding the capacity of the constant current control. If the input voltage drops below minus 15%, the appliance can no longer be operated.

Because the load-voltage may be considerably lower than the no-load-voltage, especially in case of a weak power supply, in a case of doubt a voltage measuring should be carried out during the welding procedure.

When welding with 400 V input, the primary current is approximately 10% of the welding current.

Example: welding current 1600 A = primary current abt. 160 A.

The mains must be capable of supplying this primary current with minimum fluctuation to voltage. Since the flow of current is only short (max. 0,8 sec) mains fuses of considerably reduced rating may be used, provided, of course, that they operate with sufficient time-lag. Quick acting fuses (including safety cut-out switches) may prevent operation of the appliance.

Fuses with lower ratings than indicated under table 2.1 may be used if less than the full capacity of the power source is required in operation.

If a mains plug with a lower rating is chosen, for example 16 A instead of 32 A, only mains fuses with a maximum rating equal to that of the mains plug may be used, in this case 16 A. The mains connection cable must have a cross-section sufficiently large to ensure that undervoltage is kept within the margin of tolerance. All cable cross-sections and mains fuses must comply with technical regulations and requirements of electricity suppliers.

An overvoltage of 6% should not be exceeded, since otherwise the input rectifier may be destroyed.

2.3 The Welding Gun

In drawn-arc stud welding the welding gun is used to generate the arc between stud and workpiece, and to unite the two welding pools at the end of welding time.

There is a choice of two different concepts. The guns **K 22 to K 26** have an automatic length adjustment facility, i.e. maintenance of the pre-selected lift is guaranteed independent of protrusion, variation of stud lengths within normal tolerance and minor deviations from the vertical position of studs in relation to the workpiece. However in case of very short welding cycles (below 100 ms) the necessary coupling does not react fast enough. Therefore we recommend the **SK 14** gun without length adjustment specially for short-cycle stud welding. It should be used for studs with only very minor variations in length and when constant conditions for the positioning of the welding gun apply.

The gun SK 14-ISO is different from the gun SK 14 as there is no adjustable lift stop. That is why the total piston stroke of app. 4 mm is permanently available. The gun SK 14-ISO is recommended for welding insulation pins (see figure 38). The gun SK 14 short features short length for use under cramped working conditions.

In stud welding, lift and protrusion are important parameters. In most cases they can be selected to fit stud diameters, according to figure 2. The position of the weld or the kind of surface on the workpiece may necessitate some adjustments. In such cases, optimal settings should be obtained through test welds.

The length of lift is the vital factor in determining the form of metal melting at the tip of the stud. In case of major deviation from optimal values, cavities may form in the welding pool. Moreover, if the lift is too small, an increase in the number of droplet short circuits will destabilize the welding process. The protrusion (see figure 4) will determine the form of the welding collar around the welded stud. In some cases, especially when welding onto a vertical wall, settings other than those listed may be selected. If the plunge is too shallow, this will lead to pores and undercuts in the weld zone. If it is too deep, the welding pool will splash out to the side or upwards with the risk



of blockage to the downward movement of the stud. The setting of protrusion is described in section 3.2.9.

For studs above 14 mm the plunging movement should be damped. This is achieved through adjustable plunge damping. (For settings refer to Section 3.2.12).

2.4 Technical Data on Stud Welding Guns CLASSIC

Technical Data	SK 14 (short)	SK 14-ISO	SK 15	K 22	K 22-D	K 24	K 26
Stud welding with ceramic ferrule Weldable stud range Ø (mm) ¹⁾	4 - 12	4 - 12	4 - 12	4 - 14	4 - 19	13 - 22	13 - 25
Short cycle stud welding Weldable stud range Ø (mm)	3 - 12	3 - 12	3 - 12	6 - 12	○	-	-
Stud welding with shielding gas Weldable stud range Ø (mm)	3 - 12	3 - 12	3 - 12	3 - 16	○	-	-
Adjustable hydraulic damping of piston, for studs from abt. 14 mm Ø	-	-	-	○	●	●	●
Lifting ring system with length adjustment	-	-	-	●	●	●	●
Adjustment of stud length variations up to ... (mm)	-	-	-	8	8	8	8
Standard support by ... legs	2	2	2	2	2	2	3
Lifting range from...to (mm)	0 - 4	-	-	1 - 4.5	1 - 4.5	2.5 - 6	2.5 - 6
Input voltage of lifting coil (V=)	60 - 90	60 - 90	60 - 90	60 - 90	75 - 90	75 - 90	75 - 90
Duty cycle lifting coil (%)	3	3	5	5	5	5	8
Welding cable (m/mm ²)	5/35	5/35	5/35	2/50	2/50	2/95	2/120
Welding cable plug (mm ²)	35	35	35	50/70	50/70	95	120
Control cable plug 4-pole	●	●	●	●	●	●	●
Control cable (m/mm ²)	5/4x1.0	5/4x1.0	5/4x1.0	2/4x1.0	2/4x1.0	2/4x1.0	2/4x1.0
Length (excluding chuck) (mm)	190 (165)	190	205	175	175	250	300
Body diam. app. (mm)	50	50	50	60	60	60	63
Height (including handle) (mm)	150	150	150	165	165	220	240
Weight (excluding connection cables) app. (kg)	0.9	0.9	1.0	1.3	1.3	1.4	2.6

● = Standard ○ = optional - = not available

1) For very high performance welding and large stud diameters we recommend a larger type of gun. In case of doubt please consult the maker or a sales representative for details.

Please note: connecting the K 22-D to K 26 guns to a 905i power source is not recommended, since all types of studs that can be processed with a 905i power source can also be welded with SK 14 or K 22 guns.

2.5 Setting Guidelines for welding with ceramic ferrule or shielding gas

The settings given in figure 2 have been tested for welds on **clean metallic surfaces** and standard type studs in **downhand position**. The decisive parameter is the actual diameter at the welding end of the stud, not the nominal diameter. Under different conditions (other welding position, or oily, scaly or primer-coated surfaces) the optimal settings must be determined by test welds. With difficult surfaces, it may be necessary to considerably increase lift and welding time, and to reduce the welding current. When welding in a horizontal position, it is recommended to select higher current, protrusion and plunging speed than the given settings, and at the same time shorter cycles and lift. Please note that at the lower end of the welding range of large appliances it may be necessary to select values higher than those listed in the chart. This is caused by the relatively long phase for building up the current, which means that for a considerable part of the welding cycle the peak current is not yet reached. This must be compensated by lengthening the welding cycle or selecting a higher current.

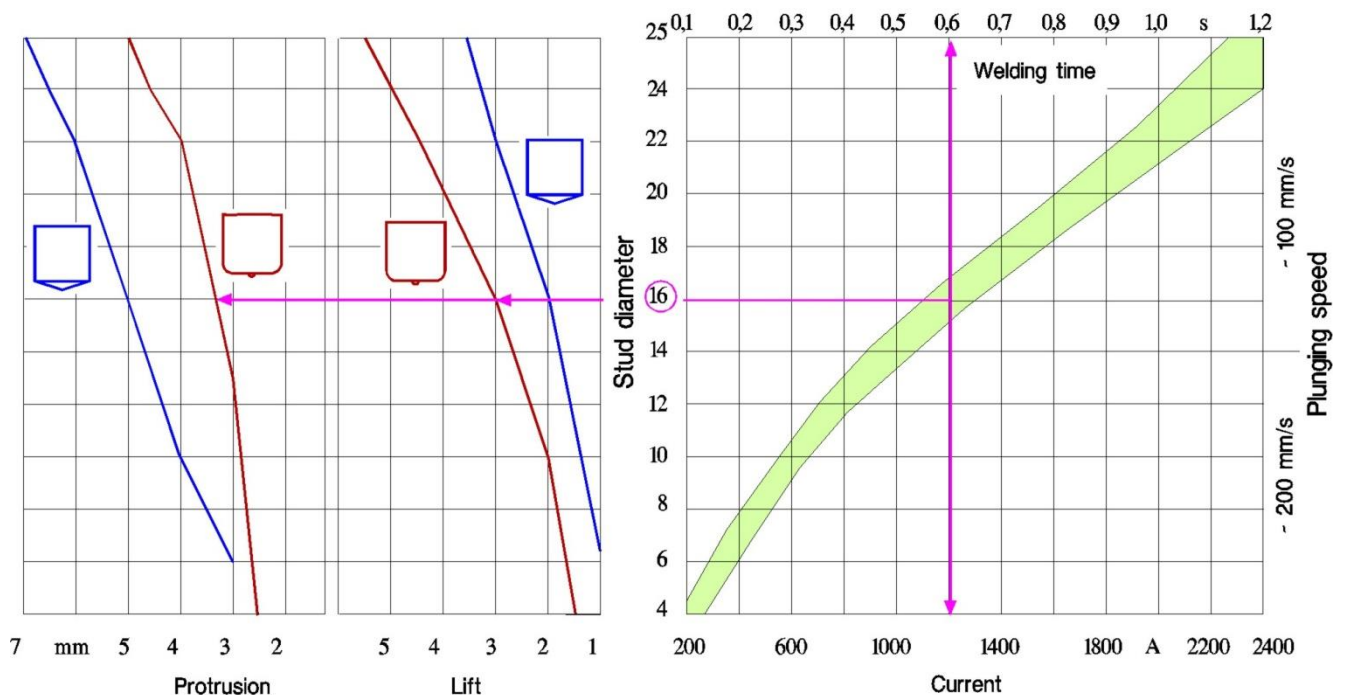

Figure 2: Parameters for current, time, lift, protrusion and damping (example for stud 16 mm diameter with flat tip)

The plunge speed is adjusted by setting the damping of the piston. In case of studs with less than app. 10 mm \varnothing guns without damper (SK 14 or K 22) should be used, or the damper should be removed (refer to 3.2.13). If the correct damper setting is selected, only very few splashes will occur during plunge, and an even welding collar without undercuts will be formed.

Before starting a series of welds, test welds according to DIN EN ISO 14555 should be carried out. For details refer to Technical bulletins DVS 0902 and 0904.

2.6 Setting guidelines for short cycle stud welding without weld pool protection or with shielding gas

Short cycle stud welding is used where it is desirable to keep the penetration on thin workpieces as shallow as possible, normally with studs ranging from M 3 to M 12 (PS type flanged studs according to EN ISO 13918). If the outward appearance of welding collars is not important, protection of the welding pool can be omitted. However, in that case a current of at least app. 100 x the nominal diameter of the stud should be selected, i.e. in case of a M 8 stud the power source should have a minimum output of 800 A. Basically, **the current should be as high and the time as short as possible**. If the time is extended beyond a certain measure to allow for a weak power source, this will result in uneven, porous welding collars.

Welding with shielding gas will result in flawless welding collars and few pores in the welding zone. Acceptable results can also be obtained with longer welding times and lower currents. For welding steel or stainless steel the use of a gas mixture M 21 (82% Ar, 18% CO₂) according to EN ISO 14175 is recommended.

In short cycle stud welding the settings depend not only on the stud diameter, but also on the thickness of the workpiece and the caliber of the gun. In the DVS-leaflet 0904 a table of setting guidelines is given. In principle, one should always start by selecting the highest current and the shortest welding time possible on the power source, and then adjust the settings after some test welds.

2.7 Material requirements

In principle, all materials suitable for fusion welding are also suitable for drawn arc stud welding. However, for some sensitive varieties of steel there is a certain risk that they may harden and become brittle by the quick heating and cooling processes involved. If two different materials are welded together (for example carbon steel with stainless steel) a new alloy will result which may be resistant to further shaping. Because of the short welding time, clean surfaces are essential for good welding results. For further details refer to literature (refer to section 13). So-called "free cutting" steels are generally not suitable for stud welding. In practice, the following combinations have proved satisfactory:

Chart 1: Recommended material combinations for drawn arc stud welding

	Parent metals	
Stud material	Non-alloy steels up to app. 0,24% C, for example S235, S355, 16Mo3	Stainless Austenite steels, such as 1.4301, 1.4401, 1.4541, 1.4571
Non-alloy steels up to app. 0,18% C, e.g. S235, 4.8, 16Mo3	Suitable, including for force transfer	For stud welding with ceramic ferrule only limited suitability for force transfer For short cycle stud welding well suited
Stainless Austenite steels, such as 1.4301, 1.4401, 1.4541, 1.4571	For stud welding with ceramic ferrule only limited suitability for force transfer well suited for up to 12 mm Ø with shielding gas For short cycle stud welding well suited	Suitable, including for force transfer ¹⁾

1) In fully austenite steels attention should be paid to the relatively high risk of hot cracks.

In addition to the material combinations listed above, heat- and scale-resistant studs may also be welded, in special cases also aluminium studs. For material combinations not previously tested, welding suitability must be determined through appropriate test welds. (For further details, refer to section 13, literature).

3 Working with the stud welding equipment

3.1 Requirements before starting-up

1. Ensure adequate power supply, according to instructions under section 2.2.
2. The power connection must be earthed according to regulations.
3. The housing of the welding power source must not have any electrical contact with the workpiece. Make sure that the insulating wheels (casters) are in perfect condition!
4. Make sure that the welding power source is standing firm in a vibration-free, dry area!
5. Make sure that there is sufficient cooling! The circulation of air must not be restricted in any way.
6. Operating the equipment in a fire or explosion danger area is prohibited. In case of doubt obtain a release for the welding operation from the security officer in charge.
7. Keep a safe distance from any objects which may be affected by strong magnetic fields, such as EDP installations! Make sure that persons wearing a heart pace-maker do not come close to the welding cables!
8. Shielding gas bottles must be secured against falling over.

3.2 Starting-up of the welding gun

1. While setting up or adjusting the welding gun, unintentional triggering of the gun pushbutton must be avoided, either by turning off the power switch or by disconnecting the control cable plug from the flange socket on the power source.
2. Screw the desired chuck on to the adapter screw of the gun, slightly tightening it with a wrench .
3. Using the counter-sink screws and washers supplied, attach the two legs to the desired footplate. Initially, do not tighten the screws.
4. Insert the desired ceramic ferrule grip (when welding with a ceramic ferrule) or the supporting tube (in case of short cycle welding or welding with shielding gas) into the footpiece, pushing it to the stop. Secure the ceramic ferrule grip or the supporting tube with the screws at the sides of the footplate.
5. Insert a suitable stud into the chuck, pushing it up to the stop.
6. Slide the footplate with the legs in the damping guides of the gun, so that the tip of the stud reaches approximately the same height as the ceramic ferrule grip or the supporting tube.
7. Move the footpiece until the stud is centrally seated in the bore of the ceramic ferrule grip or the supporting tube (see figure 3). Then tighten the counter-sink screws of the footplate.

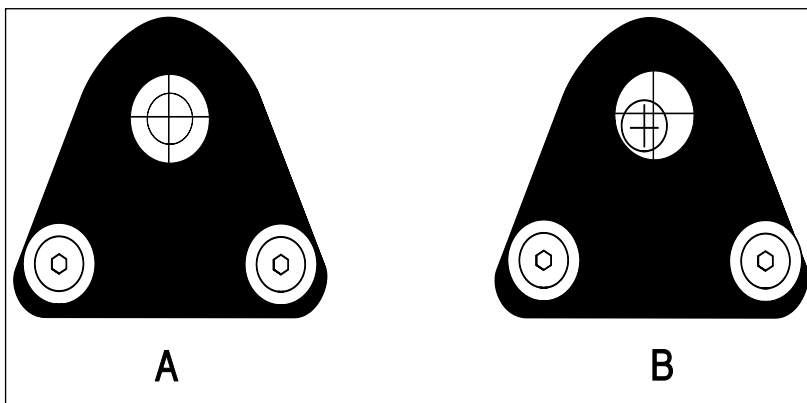

Explanation:

A: Correct centering of the footplate

B: Inaccurate centering of the footplate will cause blockage of the plunging movement of the stud.

Figure 3: Centering of the footplate

8. **Only when welding with a ceramic ferrule:** Place a suitable ceramic ferrule into its grip. Check the centering of the footpiece by manually pulling back the piston of the gun and then slowly releasing it again. The stud should then move forward without pushing the ceramic ferrule out of its guide. If the ceramic ferrule is pushed out, loosen the footpiece and improve its centering.
9. Slide the footpiece with the legs in the damping guides until the correct protrusion is reached, see figure 2. Figure 4 shows a diagram of the supporting device.

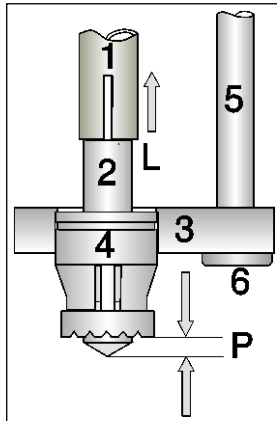

Explanation:

- 1: Chuck
- 2: Stud
- 3: Footplate
- 4: Ferrule grip
- 5: Leg
- 6: Screw
- L: Lift
- P: Protrusion

Figure 4: Diagram of the gun setup

10. **Setting of the lift (except SK 14, SK 14 short und SK 15):** Open the rear cap of the gun. Behind it there is an adapter screw for adjusting the lift in steps of 0.5 mm. (figure 5). **Do not set any in-between values!** Select lift settings according to figure 2.

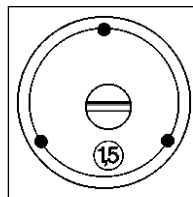

Figure 5: Selecting the lift (except SK 14, SK 14 short und SK 15)

11. **Setting of the lift (only SK 14, SK 14 short and SK 15):** A set screw with a view box is mounted on the rear of the gun. (Fig.6). The figure displayed in the view box is a measuring quantity for calculating the piston stroke. The piston stroke is always 1 mm more than the figure displayed. This ensures that even if the minimum of 1 mm is set, a lift can still be carried out as long as the protrusion is not set too high. The SK 14 gun has a rigid piston; therefore the figure shown in the view box is equal to the lift only if the protrusion is set at exactly 1 mm. The actual lift (length of the drawn arc) must therefore be calculated as follows:

$$\text{Lift} = \text{value displayed} + 1 \text{ mm} - \text{protrusion}$$

The lift can only be adjusted in 0.5 mm steps. **Do not try to set any intermediate values!** Follow the instructions according to figure 2 when setting the lift.



Figure 6: Setting of the lift (series SK 14 and SK 15)

12. **Selection of damping (K 22-D, K 24 and K 26 guns only):** The damping adjustment screw is situated between the two legs at the front of the gun. In general, damping is only used with studs from 14 mm in diameter, to prevent splashing of the welding pool while the stud plunges. The required plunging speed is about 120 mm/s. If the plunging speed is set too low (damping force too high), this can lead to a “cold plunge” of the stud and consequently cause lack of fusion. The values given in table 2 apply to medium-weight studs and welding in a downhand position (PA position). Preferably set damping too low rather than too high! Carry out test welds prior to starting series production!

In the **Version A** damper, adjust the setting disc with a screwdriver until the notch is placed approximately midway between the numbers 1 and 2 on the circumference of the case of the damper (Fig 7 A).

Version B dampers are delivered preset by the manufacturer to fit each gun under normal working conditions. Adjustment of the setting is generally not necessary. If the setting is adjusted, the cable arch of the welding cable must be removed from the adapter screw of K 24 and K 26 guns. Then use the Allen key included in the delivery to loosen the set screw so that the setting disc can be moved. To adjust the setting, turn the setting disc until the screw is positioned opposite the desired figure (Fig. 7 B). Make sure that the screw is fastened again afterwards!

13. The damper can be completely removed, if necessary, and the drill hole where it is inserted closed with a locking screw (see Fig. 29). When the damper is screwed back in, it is important to set the distance L between the installation plate and the upper edge of the damper according to table 2 (Fig.7). The damper must be fastened in this position using the counter nut included in the delivery.



Fig. 7 A: version A



Fig. 7 B: version B

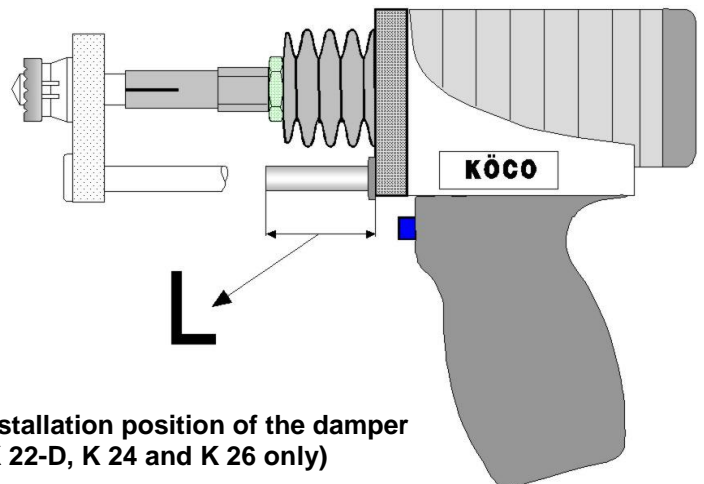

Fig. 8: Installation position of the damper (K 22-D, K 24 and K 26 only)

Table 2: damper installation length and settings

Gun	K 22-D	K 24	K 26
Installation length L (mm) for version A dampers	55		40
Recommended damper setting	1.5		
Installation length L (mm) for version B dampers	64		51
Damper pre-setting ex works by manufacturer	0.5	3	3.4



3.3 Starting-up of the Power Source

1. Insert the mains plug into the socket and lock it into position using the lock ring (if available).
2. Connect the ground cable to the ground sockets of the welding power source and the workpiece. The connection points on the workpiece must be bright metal. Lock the welding cable plugs by turning them to the right (clockwise) to the stop
3. Connect the welding and control cables of the welding gun to the correct sockets of the power source, using a welding cable extension if necessary. Lock the welding cable plugs by turning them to the right (clockwise) to the stop.

Note: In most cases, the stud is connected to the minus pole and the workpiece to the plus pole. In certain cases, especially when welding non-ferrous metals, reversed polarity may improve the welding results. The power source is suitable for welding with either polarity. Before welding with the minus pole connected to the workpiece, be sure to disconnect the second earth cable from the plus pole.

4. Switch on the welding power source at its power switch. The green pilot lamp will light up and the fan will start to operate.

3.4 Operation of the power source

3.4.1 Main menu

When the power source is switched on, it first carries out a self-test. If the outcome is satisfactory, only the green LED will light up and the set-up menu will appear on the display panel, showing the latest parameter settings used. The power source is now ready for welding.

-> Current/A	500
Time/ms	200
Gas/ms	1000
load/store	

Adjustment of settings is carried out by turning the rotary knob; the active line is marked by an arrow. The desired settings are selected by pressing the knob. Each time the knob is pressed, the arrow jumps one line further down and returns to the top line as soon as the bottom line has been reached.

Example:

The arrow points to "current". Now any current between the given lower and upper limit can be selected by turning the knob.

If the arrow points to the line "retrieve/store", stored sets of parameters can be retrieved by turning the knob anti-clockwise, and the set of parameters currently on display can be stored by turning the knob clockwise. The memory capacity allows storage of 20 sets of parameters. The process is completed by briefly pressing the knob once more.

Please note that storing a set of parameters will automatically overwrite parameter settings previously stored in that particular memory cell without previous warning.

3.4.2 Language selection

If immediately after switching on the power source the rotary knob is kept pressed for about 5 seconds, the following menu will appear following completion of the self-test:

Sprache	Deutsch
-> Language	English
Language	Francais
Lingua	Italiano

By turning the knob, the selection arrow reaches the desired language.

To fix the desired language, the knob must be kept pressed for about two seconds.

Then the confirmation of the language will be displayed for about one second.

Auswahl gespeichert
selection stored
selection memorisee
impostaz. memorizz.



3.4.3 Counter functions

Immediately following a weld (also following a „shot in the air“, which is not added to the counter reading), the current counter reading will be shown on the display panel for about 1 second.

As long as the pushbutton of the gun is kept pressed, the display will remain visible. This also applies if the machine is not unlocked (closed welding circuit), i.e. as long as the gun is not lifted off the stud just welded.

The counter counts up to a maximum of 9999999, then reverts to 1. The counter cannot be reset by the user.

3.5 Welding

Place the prepared gun on the workpiece so that the whole basis of the ceramic ferrule or supporting tube touches the surface of the workpiece. In so doing, the piston is pushed back by the length of the protrusion, and the tension spring is tightened.

Now press the trigger, holding the gun completely still during welding until the welding pool has cooled down.

Then lift off the gun from the welded stud, keeping it straight (i.e. in the axial direction of the stud) and by turning it clockwise. If it is not lifted off straight, this may open out the gripping jaws of the chuck and prevent a sufficiently tight grip on the next stud to be welded or the chuck can get loose from the adaptor screw.

Next, check the weld (by visual test and possibly other tests according to DIN EN ISO 14555) and adjust the settings if necessary.

Test welds should always be carried out prior to starting a series of welds.

3.6 Weld Testing

For testing a stud weld, there are several different methods available:

1. Visual test: A good weld will have an closed even weld collar with a shiny blue-gray surface, not dull or porous. The welded stud will have its nominal length ± 1 mm.

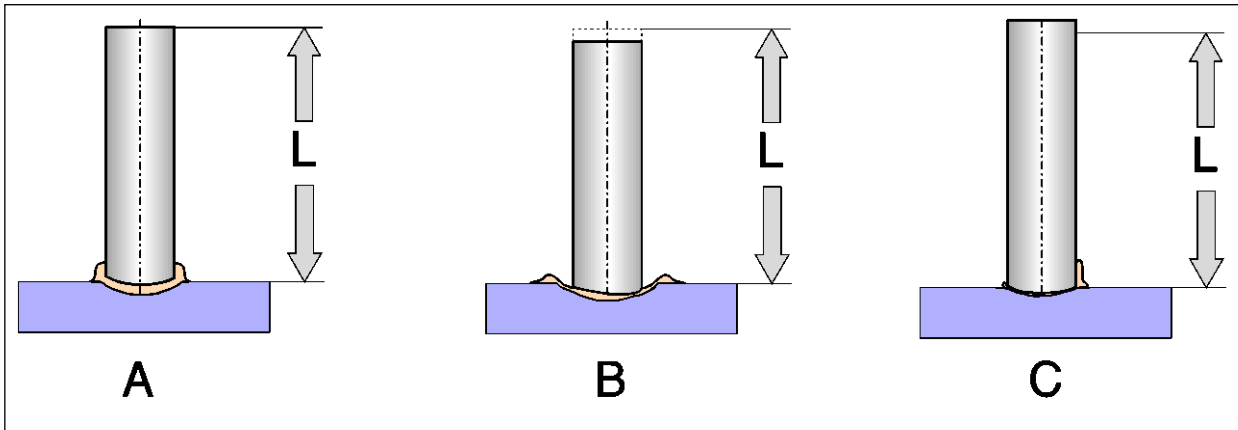
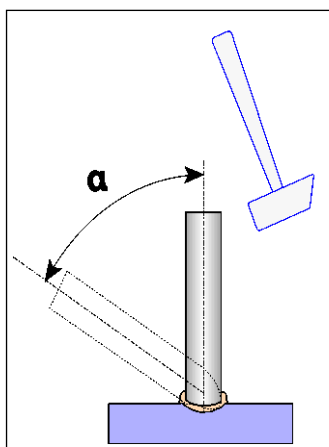

Figure 9: Assessment of visual examination

Explanation: Nominal length of stud
 A: Good weld
 B: Energy too high
 C: Energy too low

A frequent fault is a so-called plunging impediment. It occurs whenever the plunging movement of the stud is cut short and the stud comes to a halt above the welding pool. (see chart 2 figure 4). In case of only a minor impediment the plunging of the stud may not be stopped, but delayed. In this case a „cold weld“ with an incomplete connection may result, without any faults showing on the outside. (chart 2 figure 5). Therefore the final assessment of a weld should never be made on the basis of visual tests alone, without mechanical tests being carried out as well.

2. Bend test: A flawless weld will withstand bending by an angle of up to 60° without any cracks in the welding zone. This does not apply for studs designed for heat transfer (made from heat-resistant steel) and for studs with non-uniform cross section. The bend test is carried out to check the suitability of both the selected settings and the combination of materials welded together.



Bending by $\alpha = 60^\circ$ with a hammer or an affixed pipe (for leverage). Result satisfactory, if the welding zone or the heat affected zone shows no cracks or breakages

Figure 10: Carrying out a bend test

Chart 2 illustrates the assessment of welding results.

Chart 2: Assessment of stud welds

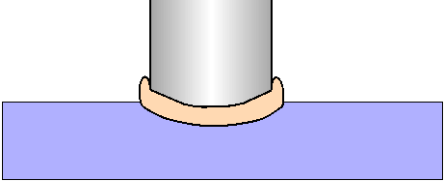
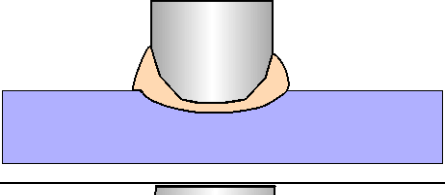
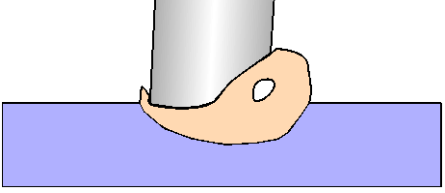
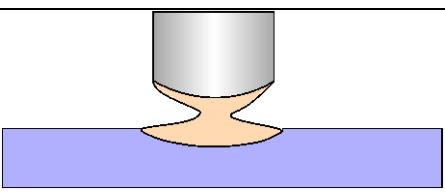
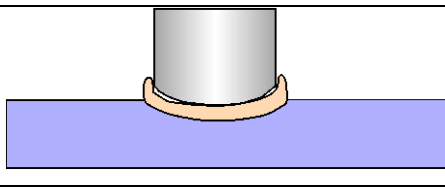
Appearance	Remarks
	<p>Good weld with ceramic ferrule</p>
	<p>Good weld with shielding gas</p>
	<p>Lopsided melting because of arc-blow effect. This can be remedied by adjusting the earth clamps, by providing compensating masses at the rim, or by turning the gun (if the welding cable is on the outside). A large lift and welding without ceramic ferrule will increase the blowing effect.</p>
	<p>Impediment to the plunging of the stud. Possible causes: 1. Friction between stud and ceramic ferrule due to inaccurate centering of the footplate or welding splashes (energy too high) 2. Droplet short-circuits between the stud and the workpiece due to too low lift setting 3. Defective gun or damping set too high.</p>
	<p>Impediment to the plunging of the stud (cold plunging). The fault can only be recognized by mechanical testing; If bent only by a small angle, the stud will break off at the welding zone. At the edge of the stud and the welding zone blank spots are visible (lack of fusion). Possible causes: As given above</p>
<p>Further details about testing and assessment of stud welds are available from literature chapter 13.</p>	

3.7 Maintenance of the Welding Power Source

Prior to any maintenance operation, the mains plug must be disconnected. In case of a fixed connection the voltage must be cut off, and the cut-off switch secured against unintentional switching on. The housing must not be opened unless the voltage is cut off.



Figure 11: Long screws to be mounted into the middle of the bottom only!

Please make sure to choose the correct lengths of screws when fastening the hood. Two longer screws must be placed in the middle of the bottom edge to join the hood with the cooling body; the remaining shorter screws must be placed in the other drillings. If the long screws are inserted, for example, in the front frame, this will cause damage to the LCD panel.

Especially when working in a dusty environment, a layer of dust may accumulate on component parts, which may hinder the cooling process and thus cause overheating inside the appliance. Moreover it reduces the resistance of insulating materials and, in connection with moisture, may lead to malfunction of the controls. Therefore the housing should be opened at regular intervals to blow out the dust. This is specially important in the case of metallic dust, which may lead to short-circuiting and damage to components. Do not aim the jet of air at pc boards, but remove the dust from these with a vacuum cleaner.

The power source must not be cleaned with a water jet (e.g. high pressure cleaning appliance). Do not use any detergents containing solvents, as these may destroy the coating or plastic components of the appliance.

There must not be any electrical connection between the metal housing of the power source and an earthed workpiece. Therefore make sure that the insulating wheels are in perfect condition if the ground has any conducting connection with the workpiece.

3.8 Maintenance of the Welding Gun

The welding gun is an electrical tool which must be kept perfectly insulated. In case of any damage to its body or cables, welding must be discontinued at once. Do not use water jets or solvents for cleaning. Protect the gun against moisture. Should it ever become wet, it must be well dried before being used again.

Chucks, ceramic ferrule grips, footpieces, etc. are subject to wearing out and must be replaced after high melting loss (scorching). For optimal current transmission the chuck must have sufficient gripping strength. If, in spite of being tightened, the jaws no longer have sufficient grip, the chuck must be replaced. Scorching marks on the thread tips in threaded studs are a sign of insufficient gripping strength.

The rear cap of the gun may only be removed for setting the lift. Especially welding must never take place without the rear cap.

Keep in mind that the stud, chuck and adapter screw are all subject to welding voltage in relation to the workpiece. Therefore, during the entire welding process, keep a safe distance from parts of the workpiece where no welding is intended, and from studs already welded.

3.9 Maintenance of Welding and Control Cables

The insulation of all cables, plugs and sockets must be kept in perfect condition. Because of the strong currents involved, all connections in the welding circuit must be tight, otherwise there is a risk of scorching. All points where cables are frequently moved, for example cable entry points, are special danger areas. There, the cross-section may be reduced through breakage of individual wires, which may lead to the remainder of the wires breaking as well and suddenly arcing over. Therefore always check cables and replace faulty parts before starting work.

Protect cables, especially connection points, against moisture. Do not clean cables with water jets or solvents.



3.10 Calibration

Stud welding equipment, which is used in the legally regulated area, e.g. in construction, or for work in which quality requirements according to ISO 3834-2 are agreed, must be calibrated at fixed intervals. In general, the calibration interval is 1 year. More details can be found in DVS code of practice 3009 and in DVS Guideline 0714. After repairs that replace components that affect the amount of welding current, the length of welding time or the lift of the gun, recalibration is required in any case.

3.11 Shutting-Down

After termination of welding the power switch must first be turned off. In case of interruption for any length of time, the appliance should also be disconnected from the mains (i.e. by pulling out the plug). Never use the mains plug in lieu of a switch, i.e. before disconnecting it, the power switch must be turned off first.

3.12 Waste Disposal

Your KOCO stud welding equipment contains valuable materials and must therefore not be disposed of together with household waste or by any other uncontrolled method.

We are registered with the “Stiftung Elektro-Altgeräte Register ® (EAR)” (Registry of Disused Electrical Appliances Foundation) under the registration number

WEEE-Reg.-Nr. DE 70903619

and will take back any appliance delivered by us from 2005 onwards free of charge for correct disposal in compliance with the relevant legislation, if such appliances are delivered to us carriage free.



4 Remedies for Malfunctions

Error signals are shown in plain text; with the word “**error**” in the first line. The error descriptions will then be listed in the following lines. If more than three types of error occur simultaneously, the display screen will be temporarily extended to show a complete list of errors diagnosed.

The following types of error may be listed: (see description field)

If “internal errors” occur (Numbers 1 to 5), please contact our service department.

Error Overheating Phase lost Gun overcurrent Mains under voltage Internal Error (1 to 5)	Please note: The error signal “mains under voltage” can also be a sign of phase failure. In the case of overheating the yellow LED will light up in addition to the error signal. In that case, allow the appliance to cool down with the fan switched on. Please follow the instructions concerning permissible power-on time (studs per minute). The red LED will generally light up with all error signals.
---------------------------------------------------------------------------------------------------------	-------------------------------------------------------------------------------------------------------------------------------------------------------------------------------------------------------------------------------------------------------------------------------------------------------------------------------------------------------------------------------------------------------------------------

4.2 Other Malfunctions

In the following chart, some malfunctions are described which can be recognized and remedied by qualified personnel with relative ease. In case you cannot solve these problems yourself, please contact our agent in your neighbourhood or our customer service department. It is important that you give us details of type and series number of your appliance, as well as an exact description of the malfunction.

Malfunction	Cause	Remedy
Piston of the gun does not react to triggering	Disconnection in the control cable to the gun	First connect the gun directly to the power source and trigger it once more. If the malfunction does not occur again, the fault is in the control cable extension. If the malfunction occurs again: Check the gun with an Ohm-Meter. Normal resistance of the coil is app. 20 Ω (SK 14 app. 38 Ω). The magnet is connected to points 1 and 2, the trigger to 3 and 4 (standard) or to 2 and 3 (special model). If the fault is still not remedied, the plug and socket connections should be checked next.
	The piston of the gun has got stuck	Try to move the piston by hand. There must not be any unusual friction. In the K 22 to K 26 guns the total range of piston movement is app. 15 mm, in the SK 14 app. 5 mm
	Magnetic coil under continuous current	Turn off the power source, then switch it back on, watching the piston of the gun (Do not trigger it). The piston must remain unmoved. If the magnet attracts it immediately, there is a defect in the control. Note: the magnetic coil will burn out if kept continuously under current even for a short time!

Malfunction	Cause	Remedy
Faulty welding result in spite of correctly set welding parameters	Surface of the workpiece oily, greasy, rusty, zinc-coated or painted, etc.	Clean the surface of the workpiece in the welding area and at the ground connection points. The best results are obtained on bright metal surfaces. On zinc-coated parts, only welding without ceramic ferrule (short cycle stud welding) will produce satisfactory results.
	Mains or welding circuit voltage too low	Make sure that permissible cable length and correct diameter are chosen.
Welding results unreliable (sometimes good, sometimes bad)	Function of gun irregular	After operating the gun for a longer period, scattering in the lift will increase. Generally, it will be below the selected setting. This means an increase in the number of droplet short-circuits and splashes. Because of the lower voltage in the arc, the energy remains below the desired level. Have the gun repaired by our customer service.
	Blowing effect through difficult shape of the workpiece	For details about measures to reduce the blowing effect refer to section 13 (literature).
	Lift (arc length) too small	Increase lift (arc length) to obtain less droplet short circuits and smoother welding process.
Welding time is cut short when the trigger button is released during welding	When connecting the control cable, the positions of two lines (No. 2 and No. 3) were reversed.	Connect cables correctly. Please note: When the trigger button is held down throughout welding time, this malfunction will not occur, however the trigger will be subjected to considerable electrical strain. If the trigger button is released during welding, this will immediately interrupt the welding process. When cables are correctly connected, the welding process will not be influenced by how long the trigger is held (provided it is held for at least app. 0.5 sec.)
Ignition failure during piston lift-off	Interruption of the pilot arc through inadequate contact with the tip of the stud	Make sure that the tip of the stud is in direct contact with the workpiece. This kind of malfunction frequently occurs during welding of headed studs with prick punch marks, whenever there is insufficient contact between the aluminium tip and the workpiece.
Unusually early power source cut-out because of overheating	Fan does not function.	Fan sluggish or blocked. Check fuse pos. 14.
Unusually strong heating up at some points of the welding circuit	Reduction of cross-section through partial wire breakage, scorching at loose connections	Stop welding immediately!. Replace cables! Tighten all connections within the welding circuit!

5 Pictures of the Power Source 905i

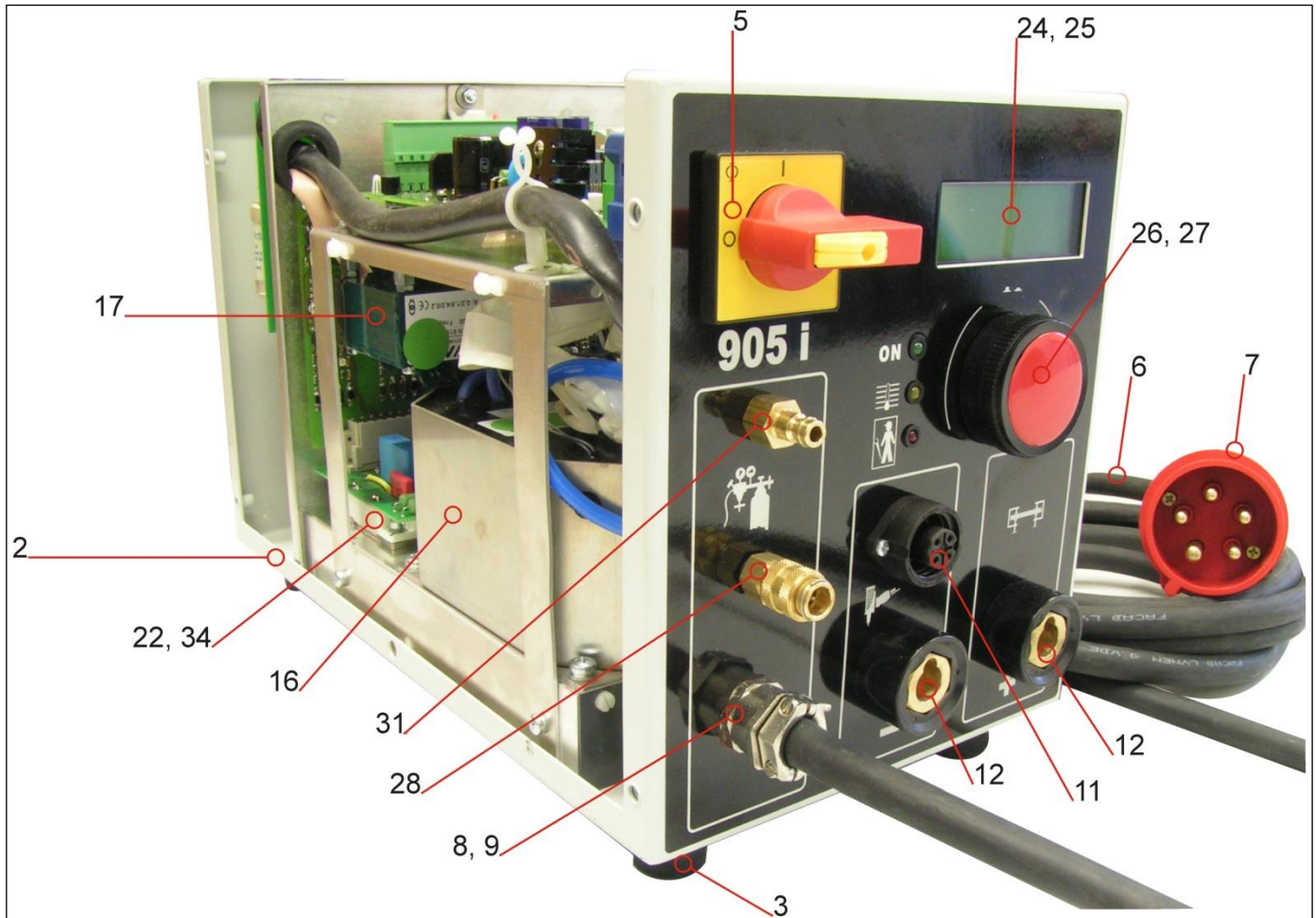

Figure 12: Front view 905i (left side)

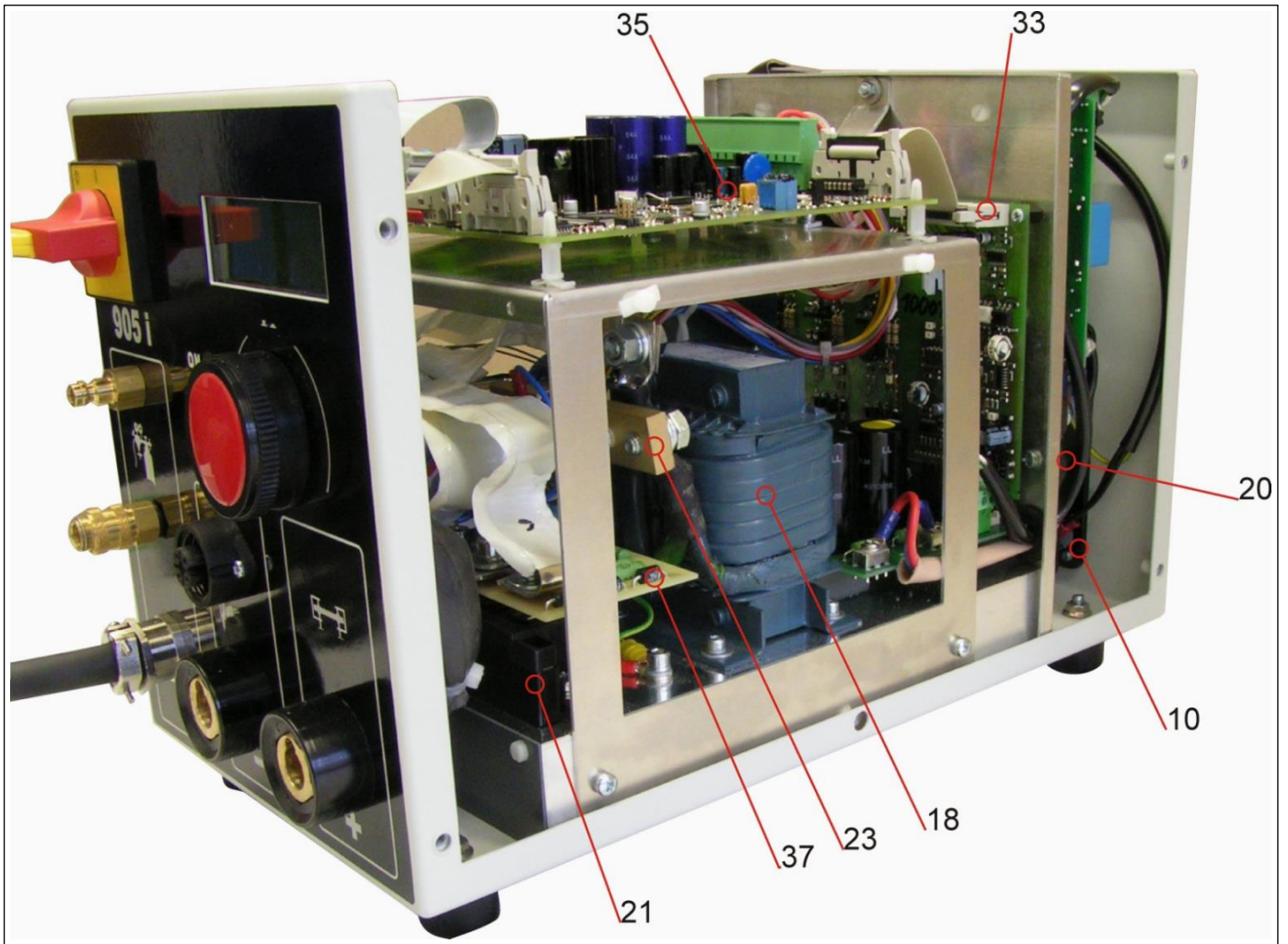

Figure 13: Front view 905i (right side)

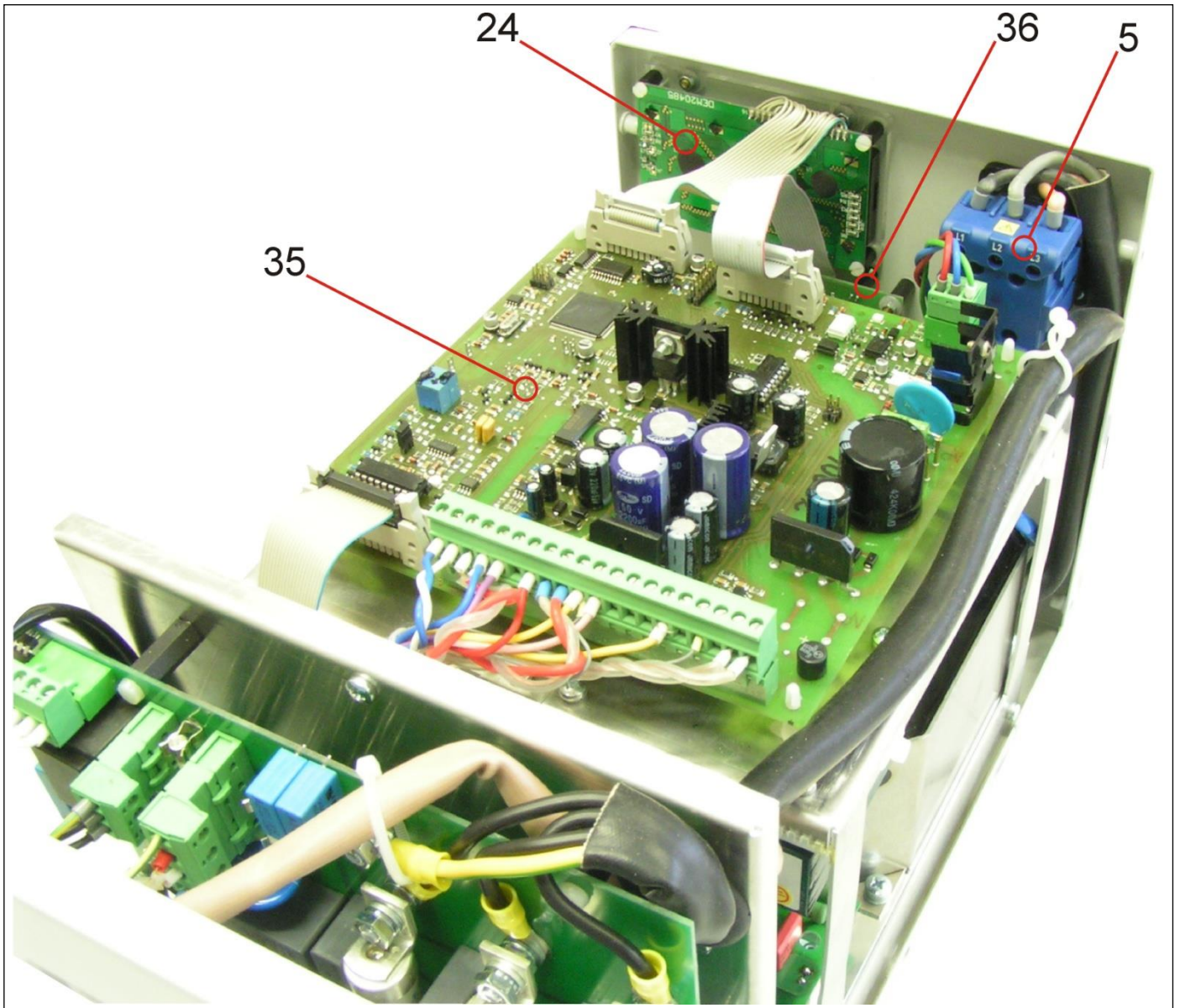

Figure 14: View from above (rear side) 905i

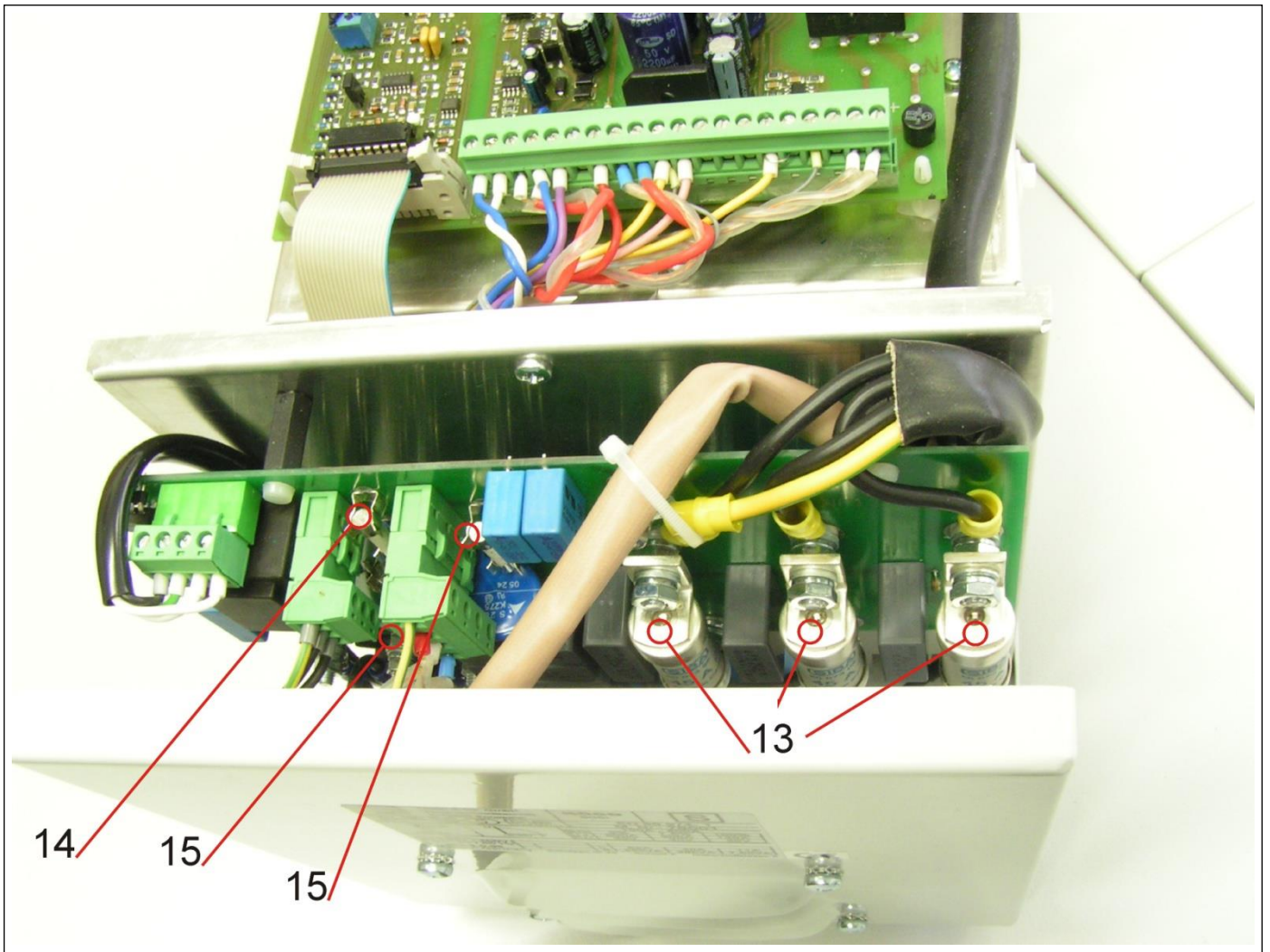

Figure 15: Fuses 905i



6 Spare Parts for Welding Power Source 905i

Pos.	No. of units	Designation	Part number
1	1	hood, laminated	320-0529-000
2	1	chassis, laminated and printed	320-6264-000
3	4	machine foot	320-0263-000
4	1	handle	320-0049-000
5	1	power switch	325-0313-000
6	1	power connection cable 4x4 mm ² , 5m	317-5069-000
7	1	mains plug 32A, 5-pole 6h CEE	325-0420-000
8	1	screwed cable gland	325-0485-000
9	1	hexagon nut for item 8	325-0481-000
10	1	fan	325-0347-000
11	1	flange socket, 4-pole	325-0079-000
12	2	welding connector	325-0017-000
13	3	semi-conductor fuse	325-0415-000
14	1	fuse 200mA 250V 5x20 "H"	325-0402-000
15	2	fuse 2A 250V 5x20 "H"	325-0391-000
16	1	power transformer	325-0690-000
17	1	control transformer	325-0713-000
18	1	choke	325-0693-000
19	1	current compensated inductor	325-0694-000
20	1	mains rectifier	330-0296-000
21	1	output rectifier	330-0312-000
22	1	IGBT module (available only together with item 34)	330-0297-000
23	1	shunt	325-0695-000
24	1	LCD panel	330-0298-000
25	1	Plexiglas panel	320-0533-000
26	1	rotary knob	325-0696-000
27	1	cap for rotary knob	320-0534-000
28	1	socket for shielding gas connexion	323-0016-000
29	1	shielding gas sealing ring	323-0022-000
30	1	shielding gas valve	323-6001-000
31	1	plug for shielding gas connexion	323-0029-000
32	1	shielding gas tube	323-0026-000
33	1	control board T42	330-0303-000
34	1	control board TB1 (available only together with item 22)	330-0304-000
35	1	control board HZG12	330-0305-000
36	1	control board HZG12A	330-0306-000
37	1	protective circuit SS1 V4	330-5189-000
38	1	control board PIQ2	330-5289-000

7 Pictures of Stud Welding Guns CLASSIC

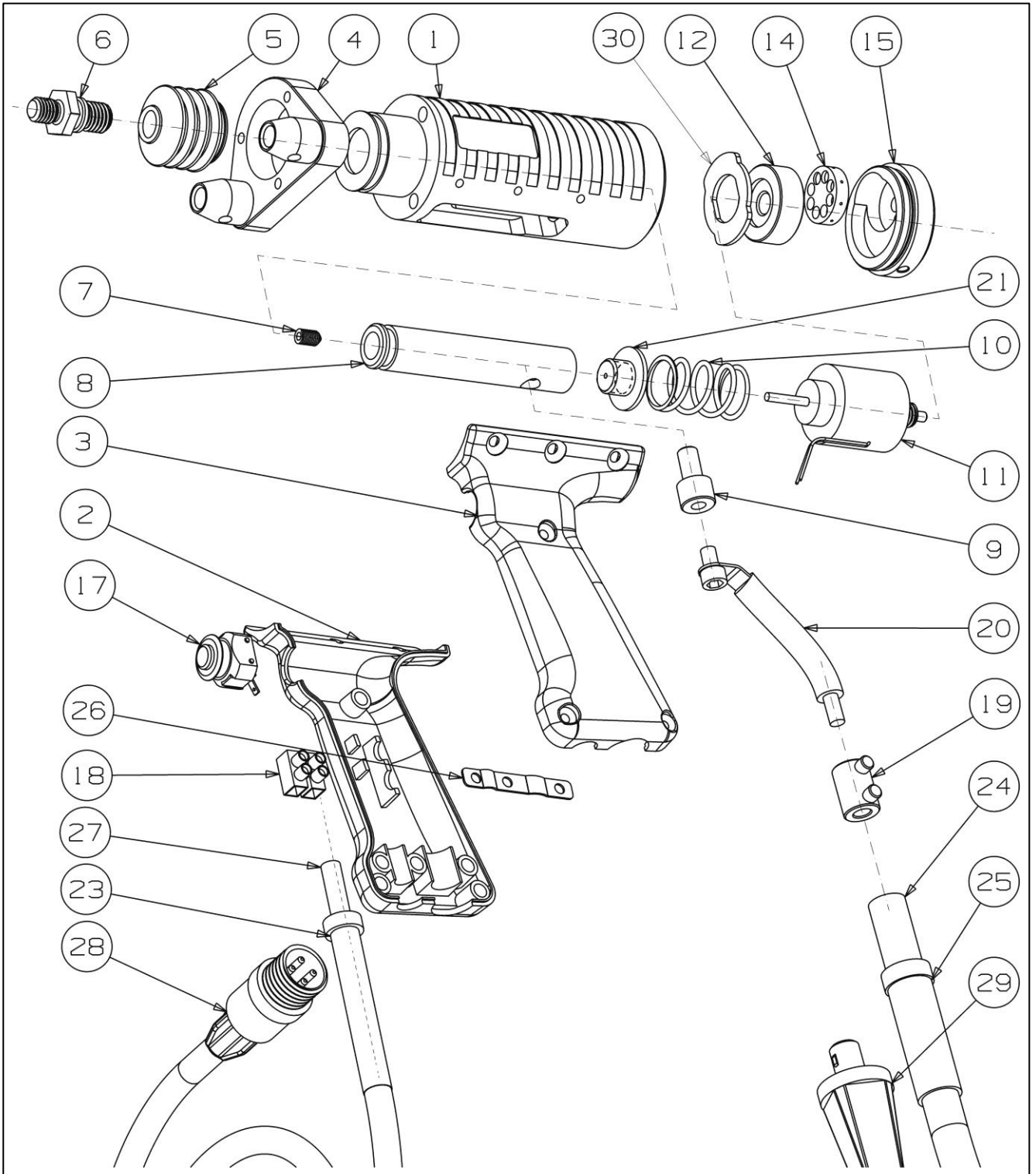

Figure 16: Exploded view of gun SK 14

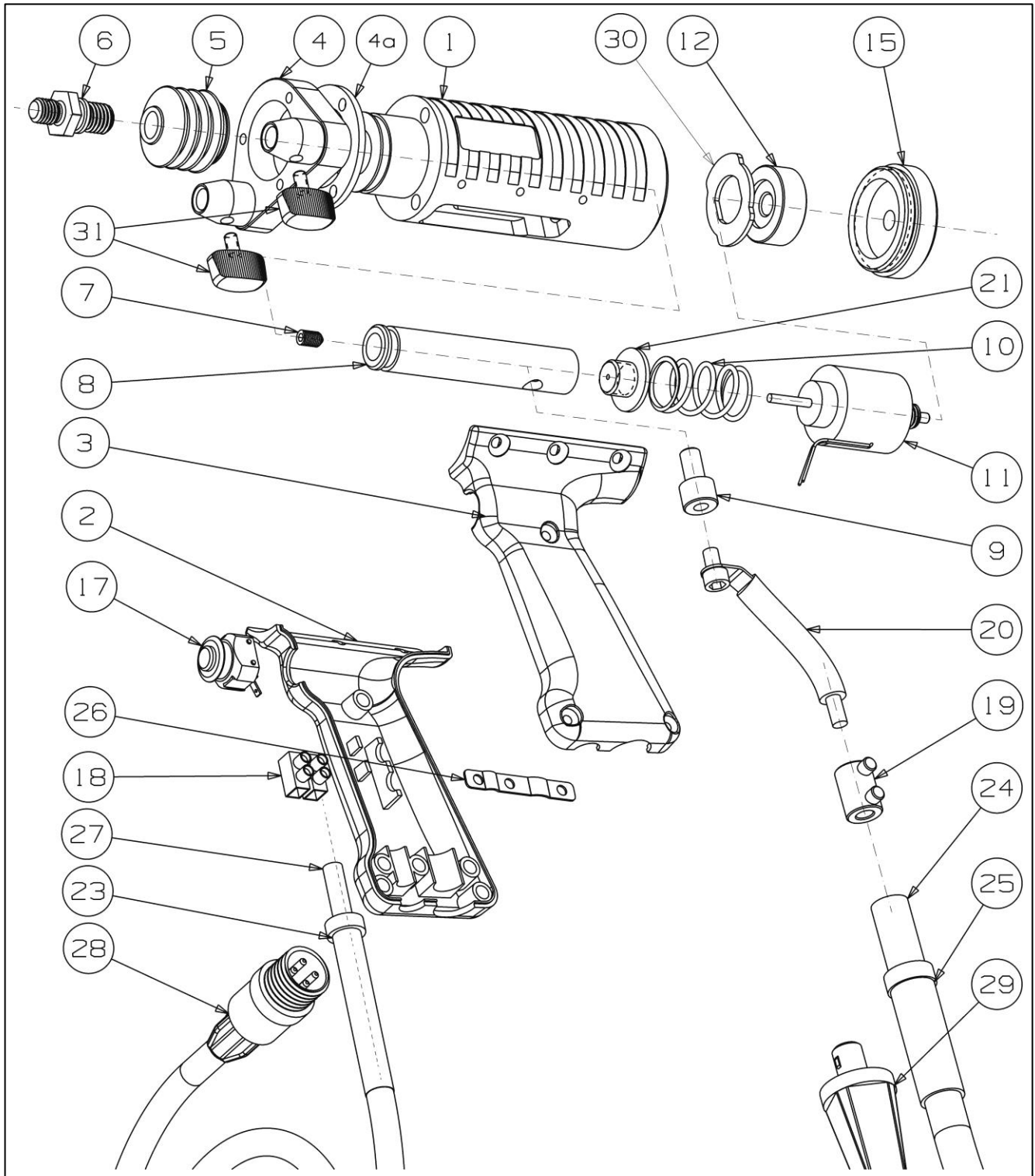

Figure 17: Exploded view of gun SK 14-ISO

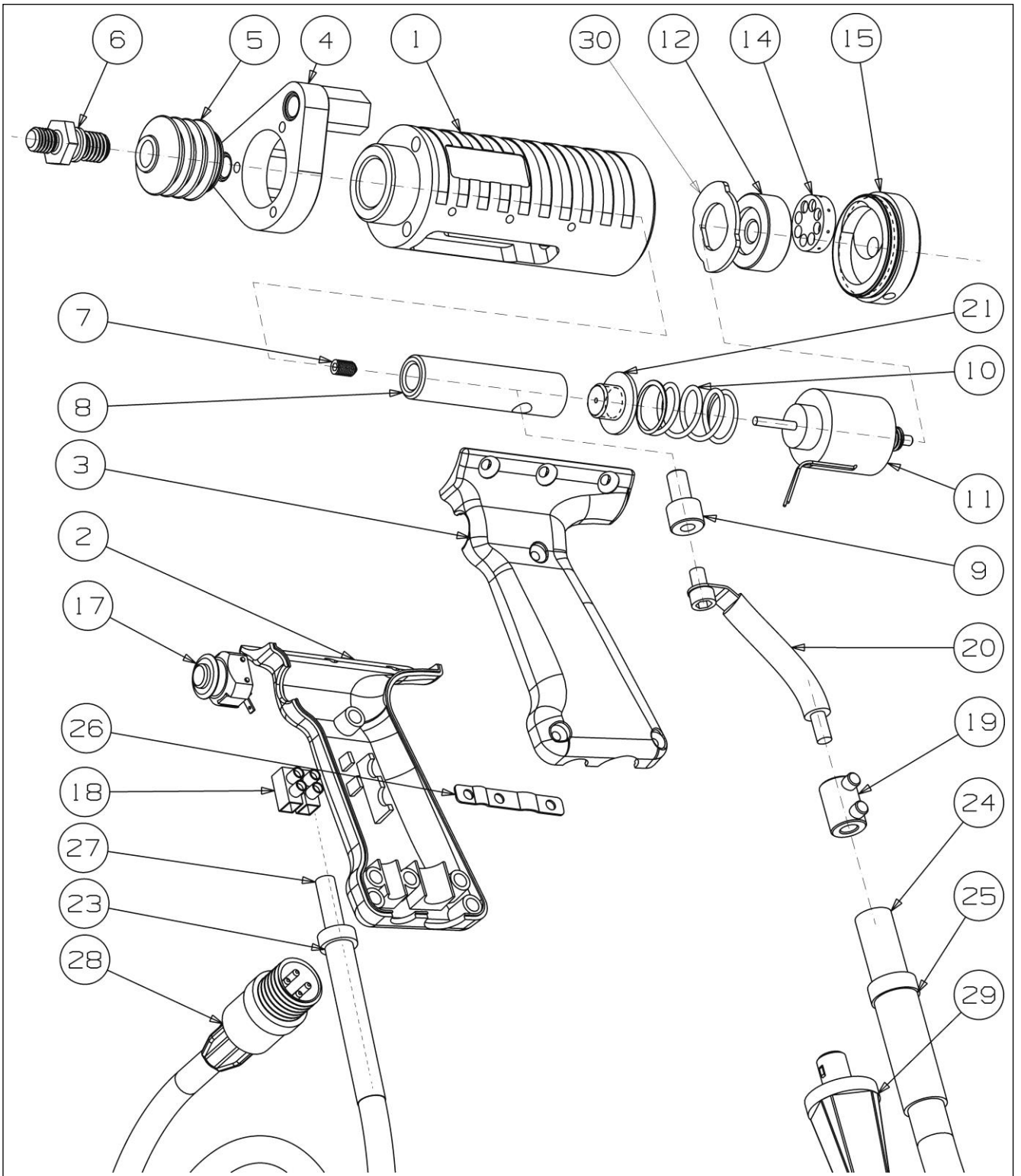

Figure 18: Exploded view of gun SK 14 short

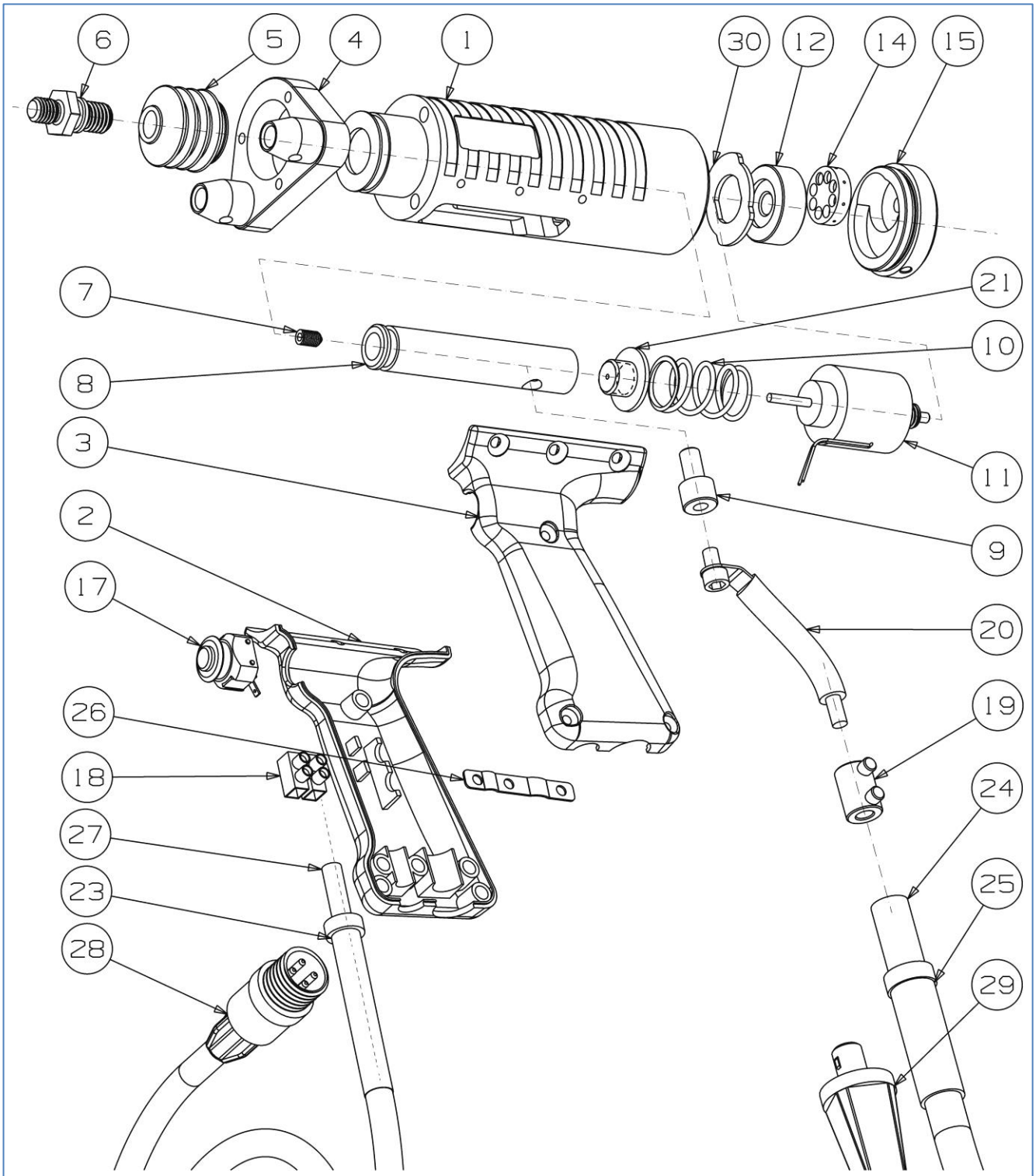

Figure 19: Exploded view of gun SK 15

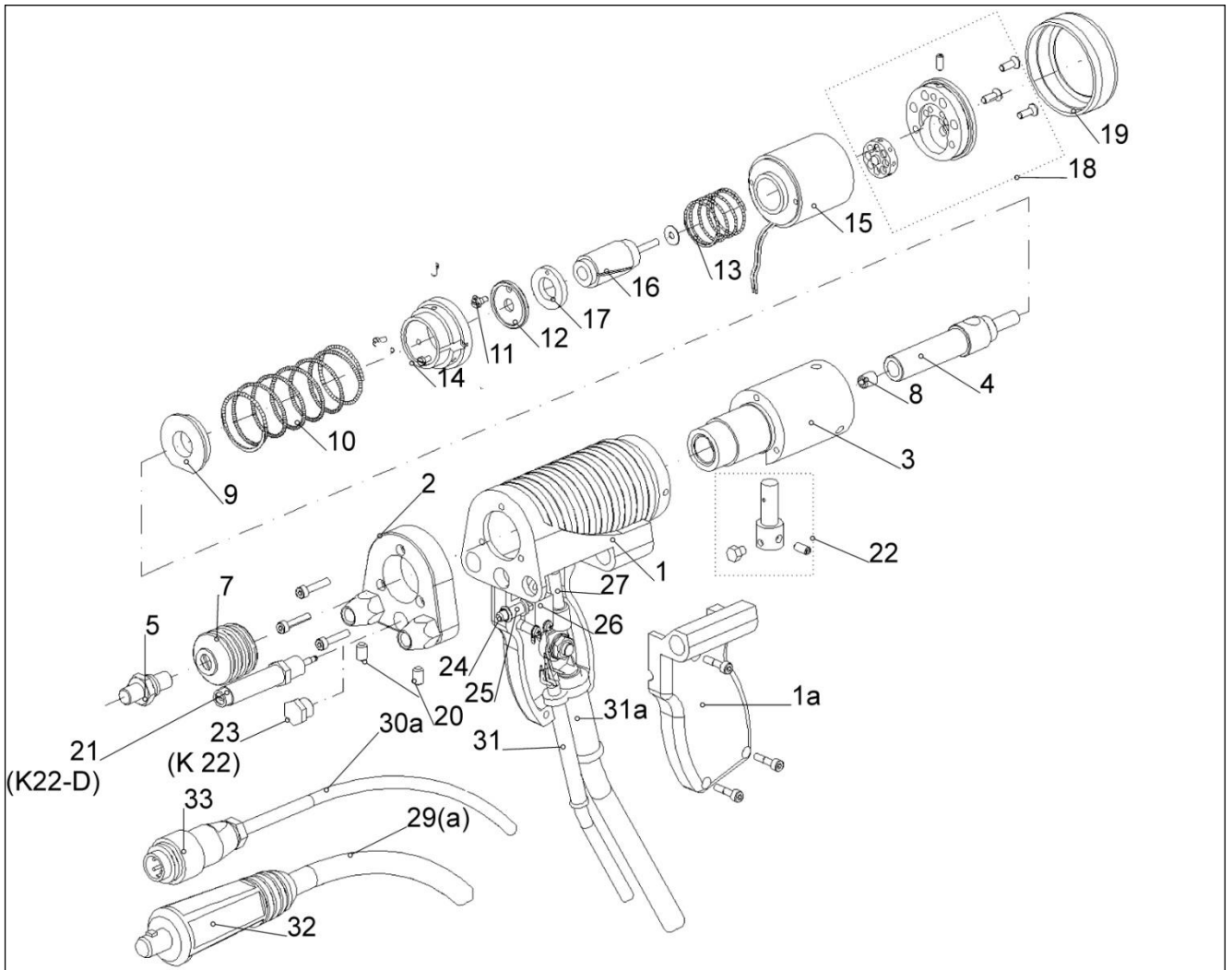

Figure 20: Exploded view of gun K 22 with option K 22-D

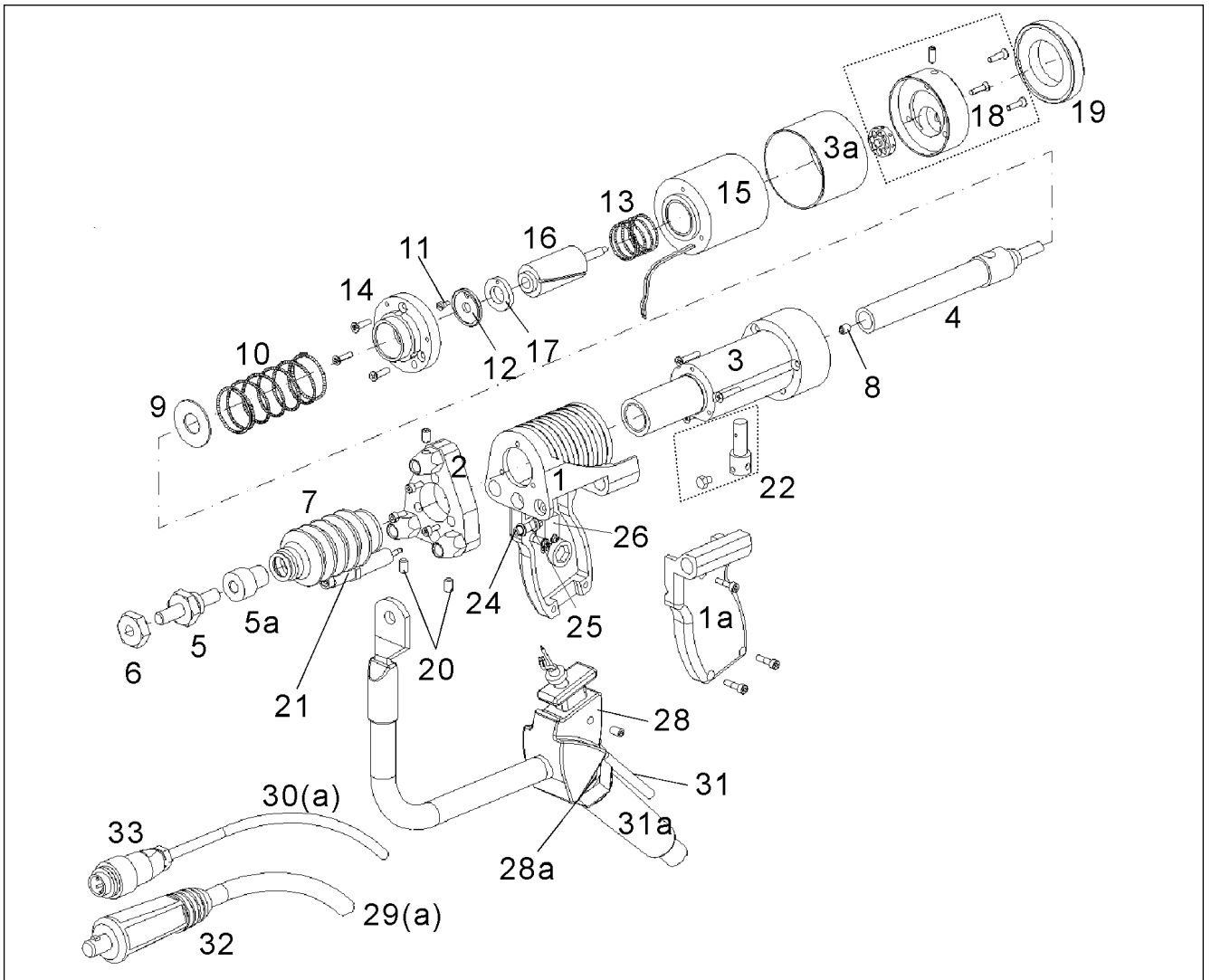

Figure 22: Exploded view of gun K 26 (from no. 400130)



8 Spare Parts for Stud Welding Guns CLASSIC

8.1 Spare parts list gun series SK 14 and SK 15

Item	Description	Part-no.			
		SK 14	SK 14-ISO	SK 14 short	SK 15
1	welding gun body	322-0601-000	322-0601-000	322-0604-000	322-0605-000
2	lower gun handle ¹	322-0597-000	322-0597-000	322-0597-000	322-0597-000
3	upper gun handle ²	322-0596-000	322-0596-000	322-0596-000	322-0596-000
4	flange plate	322-6106-000	322-6109-000	322-6113-000	322-6106-000
4a	spacer ring		322-0554-000		
5	bellows	322-0098-000	322-0098-000	322-0098-000	322-0098-000
6	adaptor screw	322-0113-000	322-0113-000	322-0113-000	322-5127-000
7	setscrew M 6 x 8	322-0220-000	322-0220-000	322-0220-000	322-0220-000
8	piston for chuck M 12 x 1	322-0576-000	322-0576-000	322-0603-000	322-0603-000
9	coupling bolt	329-0050-000	329-0050-000	329-0050-000	329-0050-000
10	compression spring	322-0594-000	322-0594-000	322-0594-000	322-0609-000
11	magnet	329-0022-000	329-0022-000	329-0022-000	329-0080-000
12	spacer sleeve	322-0598-000	322-0598-000	322-0598-000	322-0598-000
14	stop disc	322-0120-000		322-0120-000	322-0120-000
15 ²	rear cap		322-0086-000		
15 ³	lift adjustment case	322-0579-000		322-0579-000	322-0579-000
17	push button	329-0031-000	329-0031-000	329-0031-000	329-0031-000
18	lustre terminal	325-0655-000	325-0655-000	325-0655-000	325-0655-000
19	cable connector	329-0025-000	329-0025-000	329-0025-000	329-0025-000
20	welding cord	317-5113-000	317-5113-000	317-5113-000	317-5113-000
21	screwed flange	322-0097-000	322-0097-000	322-0097-000	322-0643-000
23	connection gland for control cable	325-0261-000	325-0261-000	325-0261-000	325-0261-000
24	welding cable 35 mm ² , 5 m, without plug	317-0067-000	317-0067-000	317-0067-000	317-0067-000
25	connection gland for welding cable	325-0567-000	325-0567-000	325-0567-000	325-0567-000
26	double clamp hose	325-0681-000	325-0681-000	325-0681-000	325-0681-000
27	control cable, 4 x 1 mm ² , 5,2 m, without plug	329-5233-000	329-5233-000	329-5233-000	329-5233-000
28	control plug, 4-pole	325-0240-000	325-0240-000	325-0240-000	325-0240-000
29	welding cable plug, 35 mm ²	325-0236-000	325-0236-000	325-0236-000	325-0236-000
23 – 25, 27 – 29	cable connection set 5 m, 35 mm ²	329-5243-000	329-5243-000	329-5243-000	
30	anti twist device	322-0599-000	322-0599-000	322-0599-000	322-0640-000

¹ Viewed from the assembling or disassembling position

² Applies to SK 14-ISO

³ Applies to SK 14 short and SK 15



Item	Description	Part-no.			
		SK 14	SK 14-ISO	SK 14 short	SK 15
31	wing screw		322-0631-000		

8.2 Spare parts list guns K 22, K 22-D, K 24, K 26

Pos.	Designation	Part Number			
		K 22	K 22-D	K 24	K 26
1	gun body	322-6051-000	322-6051-000	322-6050-000	322-6096-000
1a	handle cover	322-0075-000	322-0075-000	322-0074-000	322-0074-000
2	mounting plate with guide bushes	322-6045-000	322-6045-000	322-6045-000	370-6022-000
3	piston cylinder	322-6085-000	322-6085-000	322-6086-000	322-6097-000
3a	sleeve for solenoid				322-0210-000
4	piston	322-0109-000	322-0109-000	322-0112-000	322-0214-000
5	adaptor screw	329-0026-000	329-0026-000	329-0123-000	322-0212-000
5a	insulating adapter bushing				322-0213-000
6	locking nut			322-0150-000	322-0150-000
7	bellows	322-0098-000	322-0098-000	322-0092-000	322-0092-000
8	threaded bolt	322-0108-000	322-0108-000	322-0220-000	322-0220-000
9	spring guide	322-0125-000	322-0125-000	322-0125-000	322-0125-000
10	main tension spring	322-0083-000	322-0083-000	322-0083-000	322-0341-000
11	lifting ring pin	322-0200-000	322-0200-000	322-0200-000	322-0200-000
12	lifting ring	322-0201-000	322-0201-000	322-0201-000	322-0201-000
13	tension spring	322-0202-000	322-0202-000	322-0202-000	322-0202-000
14	lifting ring housing	322-0203-000	322-0203-000	322-0203-000	322-0217-000
15	magnetic coil	329-0033-000	329-0033-000	329-0033-000	329-0036-000
16	magnet core	329-0034-000	329-0034-000	329-0038-000	329-0037-000
17	anchoring disk	322-0204-000	322-0204-000	322-0204-000	322-0204-000
18	lift setting system	322-6088-000	322-6088-000	322-6089-000	322-6087-000
19	rear cap	322-0079-000	322-0079-000	322-0079-000	
20	setscrew M 6 x 8	322-0206-000	322-0206-000	322-0206-000	322-0206-000
21	damper		322-0131-000	322-0132-000	322-0133-000
22	damper stop	322-0118-000	322-0118-000	322-0124-000	322-0124-000
23	locking screw	322-0040-000			
24	switch pins	322-0103-000	322-0103-000	322-0103-000	322-0103-000
25	switch pin bearing	322-0104-000	322-0104-000	322-0104-000	322-0104-000
26	trigger	329-0030-000	329-0030-000	329-0030-000	329-0030-000
27	welding cord	329-5220-000	329-5220-000		
28	cable holder			322-0392-000	322-0392-000
28a	pressing clamp			322-0404-000	322-0404-000



Pos.	Designation	Part Number			
		K 22	K 22-D	K 24	K 26
29	welding cable, 2 m, 50 mm ² with protective conduit	329-5216-000	329-5216-000		
29	welding cable 2 m, 95 mm ² without plug, with protective conduit			329-5223-000	
29	welding cable 2 m, 120 mm ² without plug, with protective conduit				329-5225-000
29a	welding cable 2 m, 50 mm ² with plug and protective conduit	329-5217-000	329-5217-000		
29a	welding cable 2 m, 95 mm ² with plug and protective conduit			329-5224-000	
29a	welding cable 2 m, 120 mm ² with plug and protective conduit				329-5226-000
30	ready-to-connect control cable, 2,3 m, 4 x 1 mm ²	329-5218-000	329-5218-000	329-5218-000	
30a	ready-to-connect control cable, 2,3 m, 4 x 1 mm ² with plug	329-5219-000	329-5219-000	329-5219-000	
31	bending protector for control cable	325-0261-000	325-0261-000	325-0261-000	
31a	bending protector for welding cable	325-0567-000	325-0567-000	322-0393-000	322-0393-000
32	welding cable plug 35/50 mm ²	325-0234-000	325-0234-000		
32	welding cable plug 70/95 mm ²			325-0239-000	
32	welding cable plug 120 mm ²				325-0251-000
33	control cable plug 4-pole	325-0240-000	325-0240-000	325-0240-000	325-0240-000
	complete connection cable set 2 m, 50 mm ²	329-5214-000	329-5214-000		
	complete connection cable set 2 m, 95 mm ²			329-5215-000	
	complete connection cable set 2 m, 120 mm ²				329-5227-000
	complete connection cable set 5 m, 50 mm ²	329-5201-000	329-5201-000		
	complete connection cable set 7,5 m, 50 mm ²	329-5202-000	329-5202-000		



9 Pictures of Cables

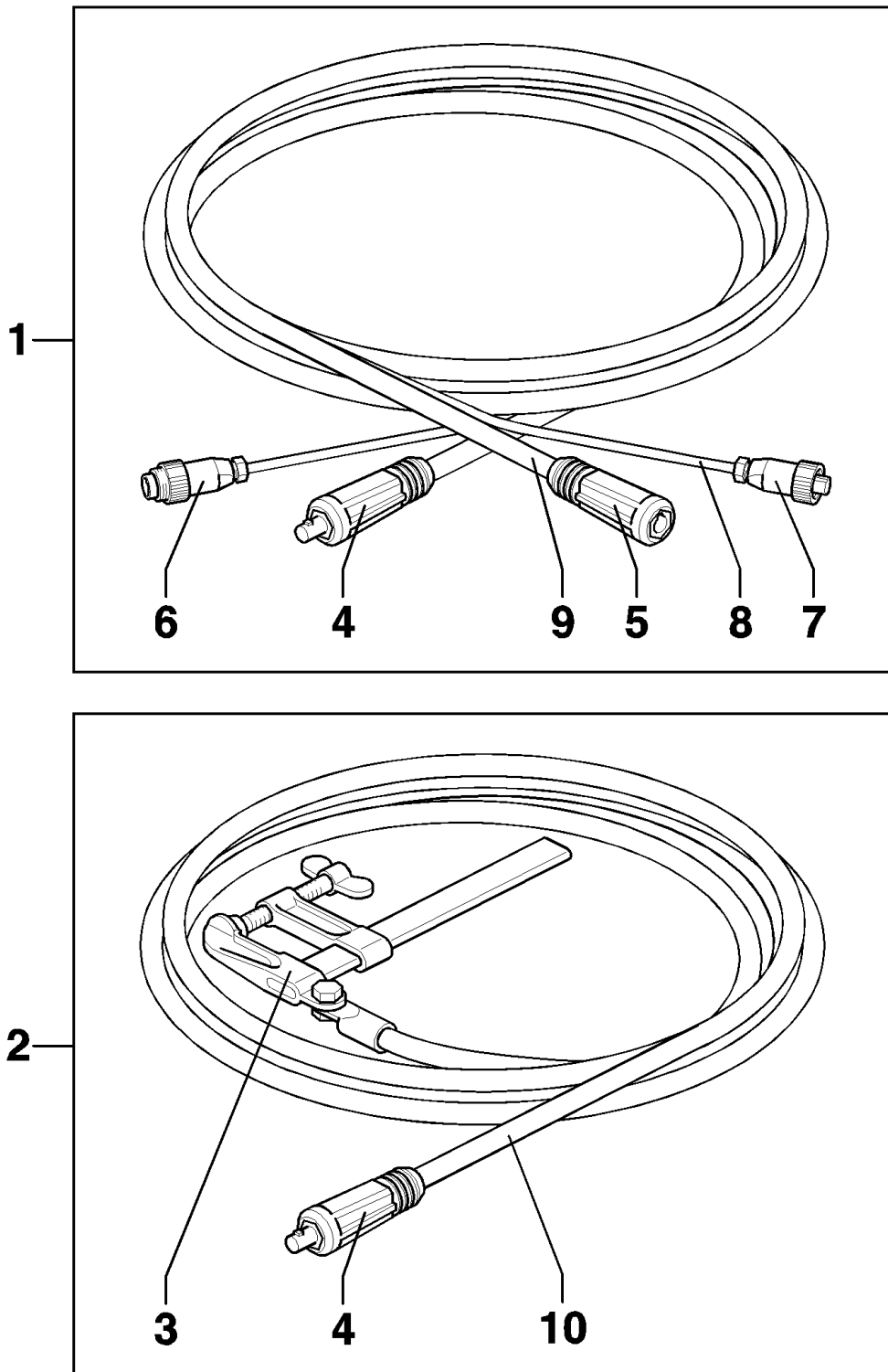

Figure 23: Welding cable extension and ground cable



10 Cable Spare Part List

Pos.	Designation	Part No.
1	welding and control cable extensions 10 m, 50 mm ² (complete set) ¹⁾	317-5015-000
1	welding and control cable extensions 10 m, 70 mm ² (complete set) ¹⁾	317-5010-000
1	welding and control cable extensions 10 m, 95 mm ² (complete set) ¹⁾	317-5014-000
1	welding and control cable extensions 10 m, 120 mm ² (complete set) ¹⁾	317-5067-000
2	pair of earth cable 10 m, 70 mm ² with pole clamp (complete set) ¹⁾	317-5031-000
3	pole clamp, jaws width 200 mm	325-0174-000
4	welding cable plug 35/50 mm ²	325-0234-000
4	welding cable plug 50/70 mm ²	325-0505-000
4	welding cable plug 95 mm ²	325-0239-000
4	welding cable plug 120 mm ²	325-0251-000
5	welding cable socket 35/50 mm ²	325-0233-000
5	welding cable socket 50/70 mm ²	325-0237-000
5	welding cable socket 95 mm ²	325-0250-000
5	welding cable socket 120 mm ²	325-0252-000
6	control cable plug 4-pole	325-0240-000
7	control cable socket 4-pole	325-0348-000
8	control cable 10 m, 4 x 1,0 mm ² including fittings	317-0065-000
9	welding cable, 70 mm ² (sold by metre)	317-0070-000
9	welding cable, 95 mm ² (sold by metre)	317-0095-000
9	welding cable, 120 mm ² (sold by metre)	317-0120-000
10	earth cable 10 m, 70 mm ² , with protective conduit	317-0066-000

1) Upon request extension cables with lengths according to customer's choice are available.

11 Schematic Circuit Diagram

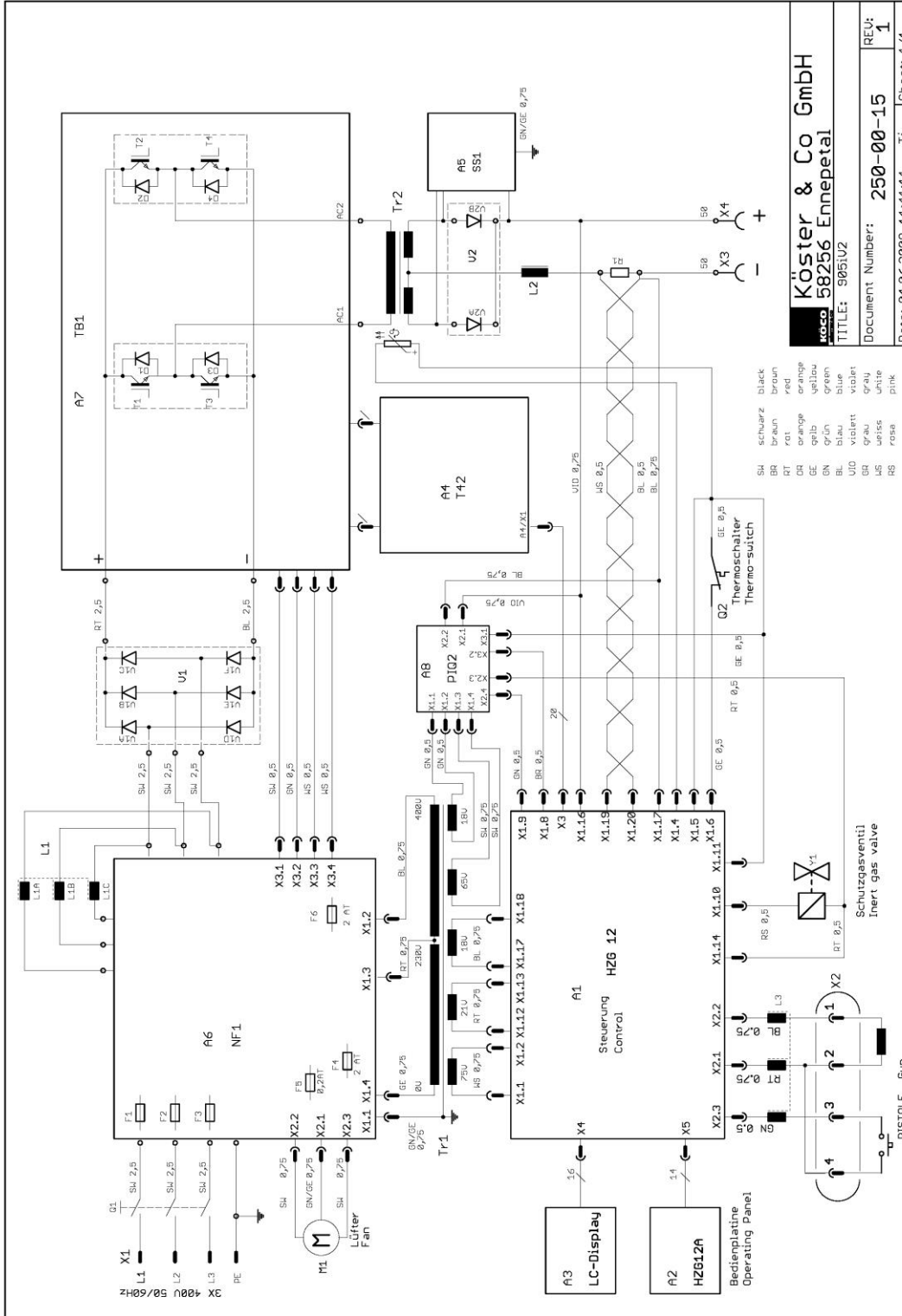

Figure 24: Schematic Circuit Diagram 905i

12 Accessories

12.1 Gun accessories for stud welding guns K 22 to K 26

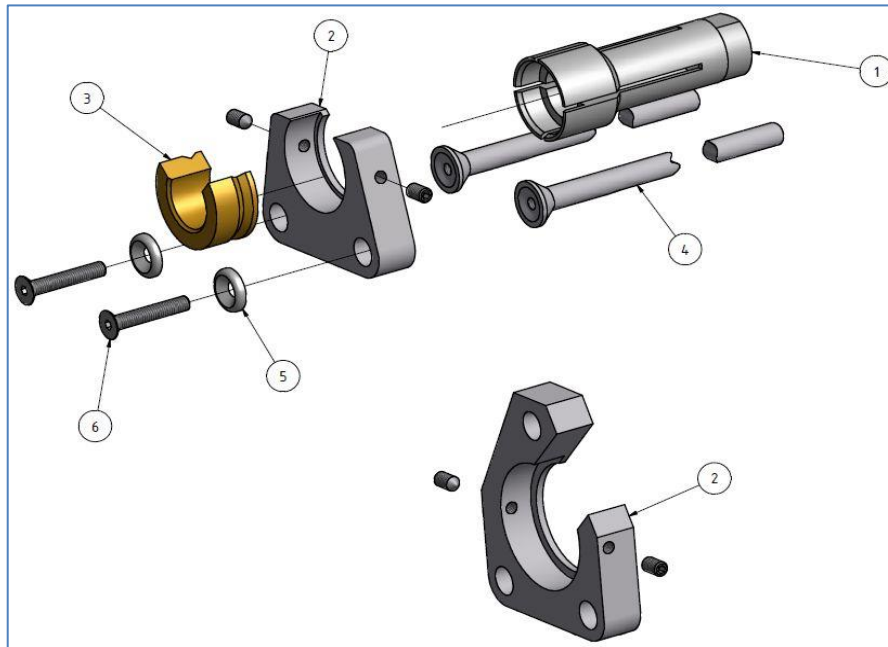

Figure 25: Gun accessories for shear connectors from 50 mm length

Stud diameter	Chuck pos. 1	Foot plate pos. 2	Ferrule grip pos. 3
6	350-0056-000	360-0116-000	355-0031-000
10	350-0164-000	360-0117-000	355-0033-000
13	350-0059-000	360-0118-000	355-0035-000
16	350-0060-000	360-0119-000 (version for 2 legs)	355-0036-000
19	350-0060-000		355-0036-000
22	350-0061-000		355-0037-000
25	350-0062-000		355-0038-000
Recommendation for studs longer than 200 mm:		360-0149-000 (version for 3 legs)	
Stud length up to (mm)			Part-No. pos. 4
K 22 and K 22-D	K 24	K 26	
140	90	70	370-0240-000
200	150	130	370-0300-000
300	250	230	370-0400-000
400	350	330	370-0500-000
500	450	430	370-0322-000
600	550	530	370-0323-000
Washer pos. 5		370-0055-000	
Screw with hexagon socket pos. 6		322-0372-000	

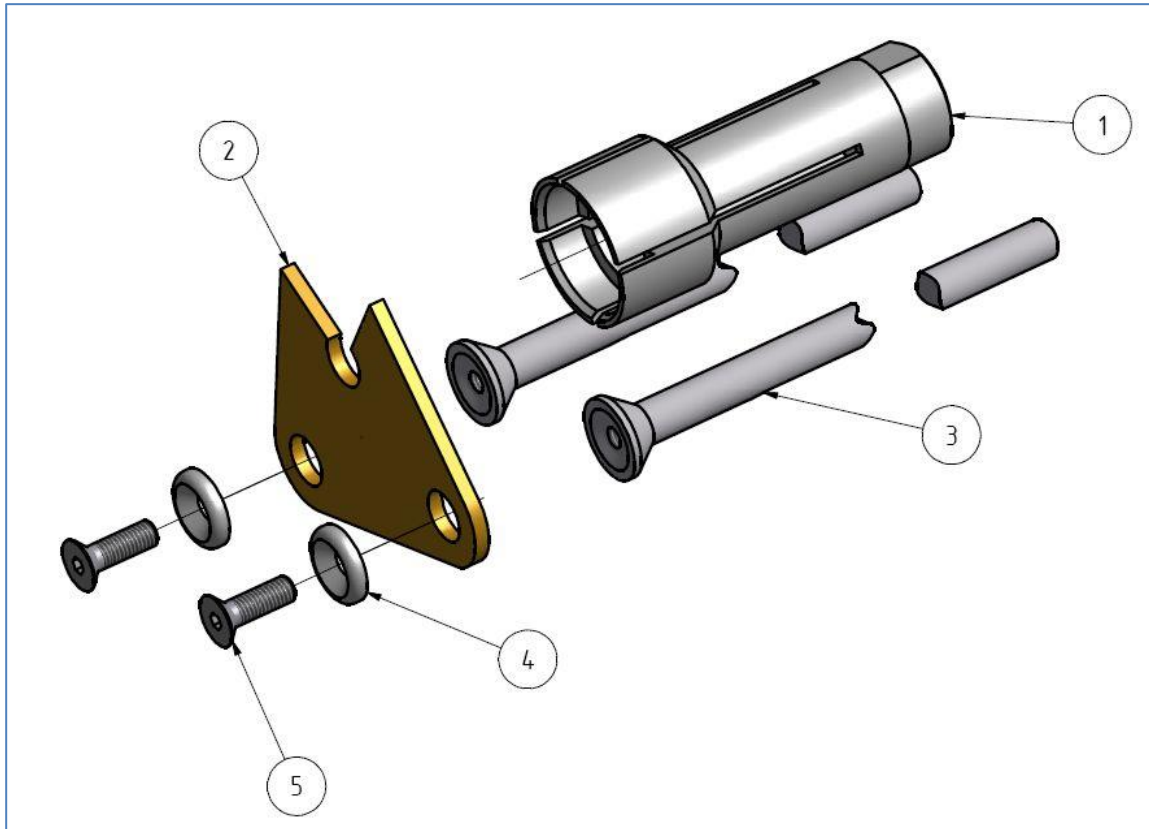

Figure 26: Gun accessories for shear connectors up to 50 mm length

Stud diameter	Chuck pos. 1	Foot plate/ ferrule holder pos. 2	Leg pos. 3	Washer pos. 4	Screw with hexagon socket pos. 5
10	350-0058-000	360-0164-000	370-0240-000	370-0055-000	322-0379-000
12	350-0059-000	360-0085-000			
13	350-0059-000	360-0086-000			
16	350-0060-000	360-0087-000			
19	350-0060-000	360-0087-000			
22	350-0061-000	360-0088-000			

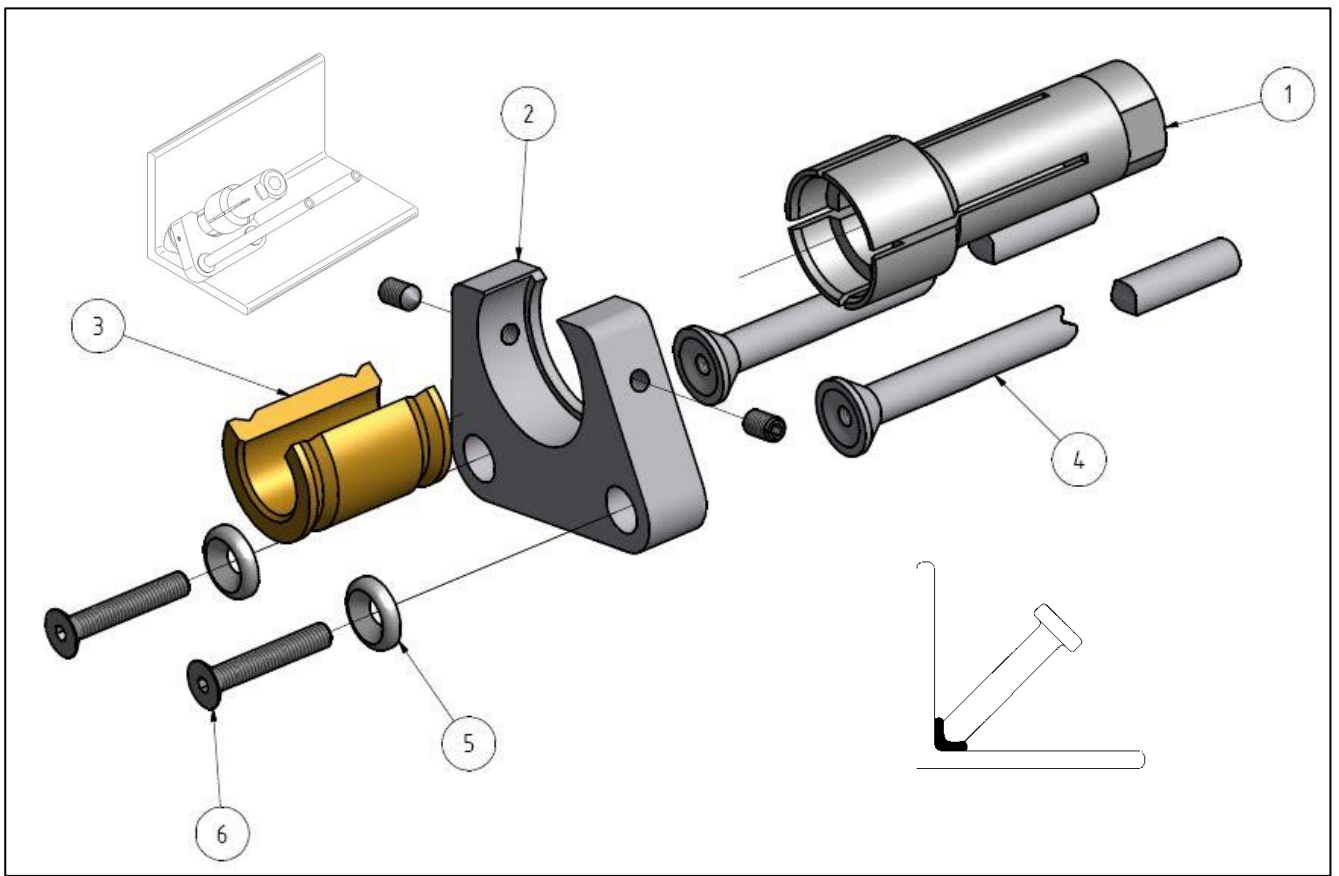

Figure 27: Gun accessories for shear connectors in an interior angle

Stud diameter	Chuck pos. 1	Foot plate pos. 2	Ferrule grip pos. 3
6	350-0056-000	360-0116-000	355-0263-000*
10	350-0164-000	360-0117-000	355-0043-000
13	350-0059-000	360-0118-000	355-0044-000
16	350-0060-000	360-0119-000	355-0268-000*

For pos. 4, 5 and 6 see figure 23.

* Discontinued types, not for new projects.

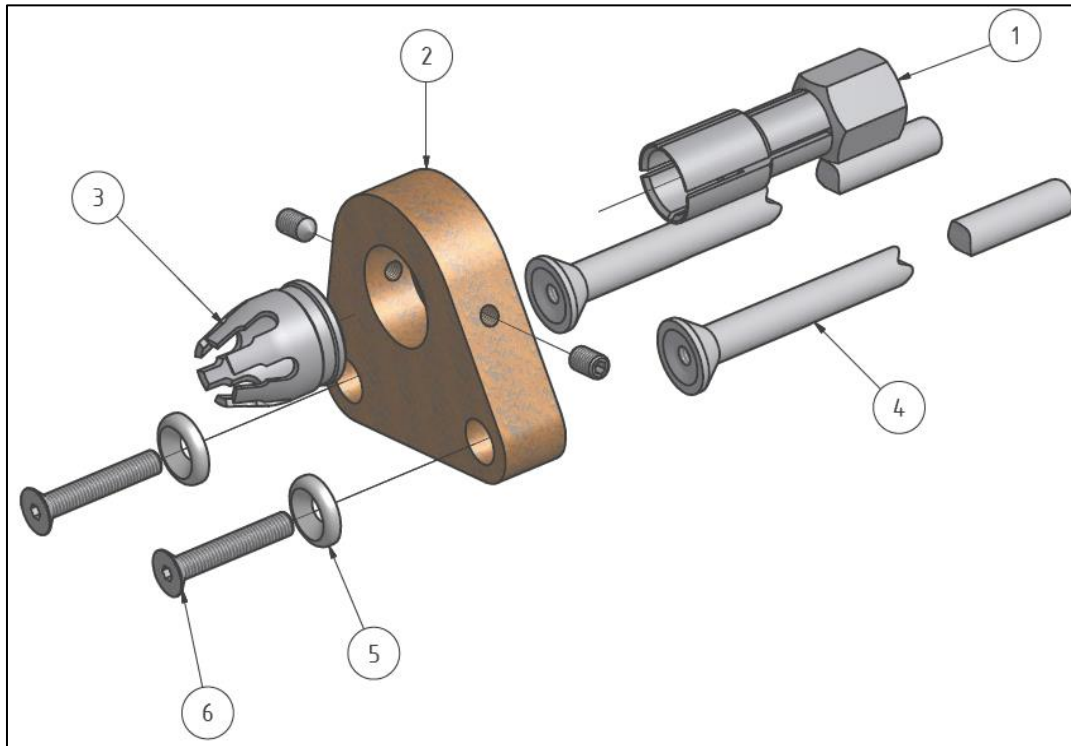

Figure 28: Gun accessories for threaded studs, tapped studs and plain pins

Type PD	Type DD	Type RD	Chuck pos. 1	Ferrule grip pos. 3	Foot plate pos. 2
M 4 x > 20	M 4 x > 20		350-0002-000	355-0001-000	360-0101-000
M 5 x > 20	M 5 x > 20		350-0003-000	355-0002-000	
M 6 x > 16	M 6 x > 16	M 6 x > 16	350-0004-000	355-0002-000	
M 6 x > 20	M 6 x > 20	M 6 x > 20	350-0005-000	355-0002-000	
M 8 x > 16	M 8 x > 16	M 8 x > 16	350-0006-000	355-0003-000	
M 8 x > 20	M 8 x > 20	M 8 x > 20	350-0007-000	355-0003-000	
M 10 x > 16	M 10 x > 20	M 10 x > 20	350-0008-000	355-0004-000	
M 10 x > 20	M 10 x > 25	M 10 x > 25	350-0009-000	355-0004-000	
M 12 x > 16	M 12 x > 20	M 12 x > 20	350-0010-000	355-0005-000	
M 12 x > 25	M 12 x > 25	M 12 x > 30	350-0011-000	355-0005-000	
M 16 x > 20			350-0015-000	355-0006-000	360-0102-000
	M 16 x > 25	M 16 x > 20	350-0015-000	355-0007-000	360-0103-000
M 16 x > 30			350-0016-000	355-0006-000	360-0102-000
	M 16 x > 30	M 16 x > 25	350-0016-000	355-0007-000	360-0103-000
	M 20 x > 25	M 20 x > 20	350-0018-000	355-0007-000	
M 20 x > 25			350-0018-000	355-0008-000	
	M 20 x > 30	M 20 x > 25	350-0019-000	355-0007-000	
M 20 x > 30			350-0019-000	355-0008-000	
M 24 x > 35		M 24 x > 30	350-0023-000	355-0008-000	



Stud length up to (mm)			Required length of legs (mm)	Part No. pos. 4
K 22 and K 22-D	K 24	K 26		
140	90	70	240	370-0240-000
200	150	130	300	370-0300-000
300	250	230	400	370-0400-000
400	350	330	500	370-0500-000
500	450	430	600	370-0322-000
600	550	530	700	370-0323-000
Washer pos. 5				370-0055-000
Screw with hexagon socket pos. 6				322-0372-000

For studs below 12 mm diameter and lengths $L > \text{app. } 6 \times \text{diam.}$ chucks with deeper grip length are recommended. Further information upon request.

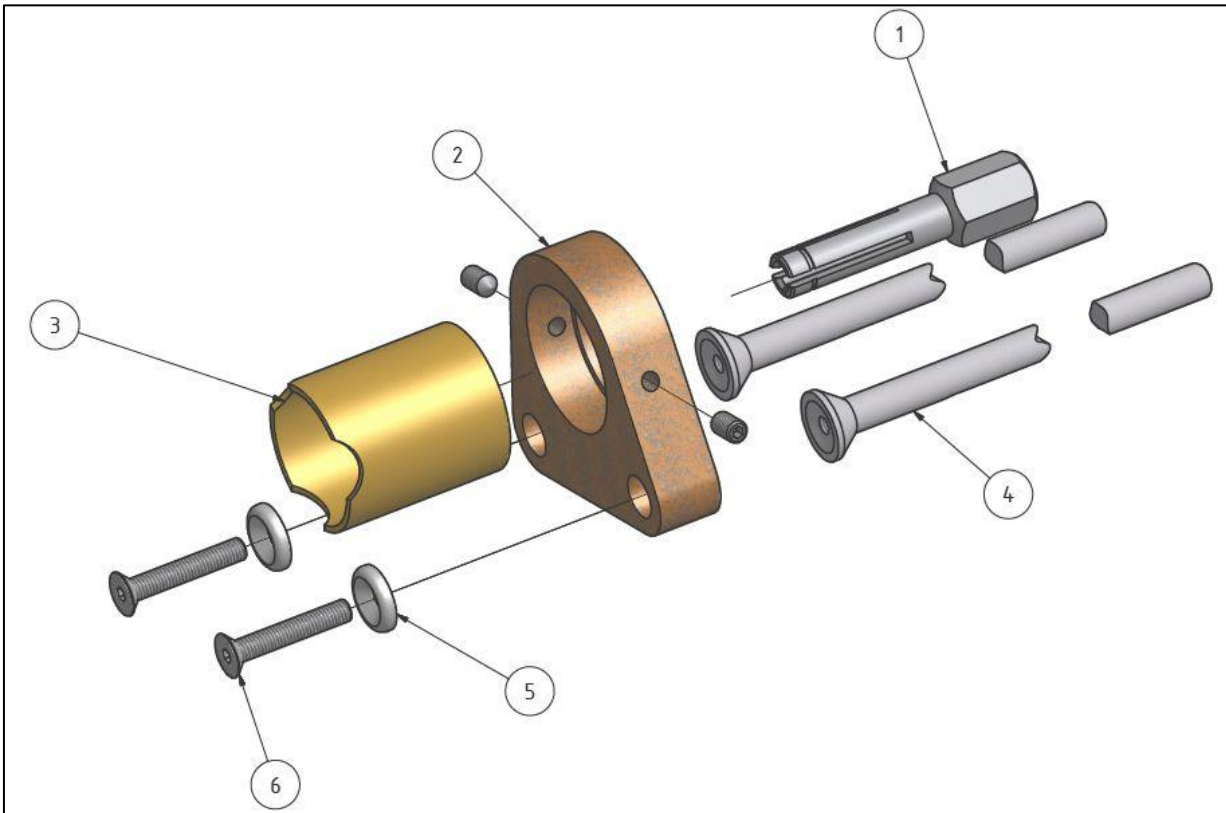

Figure 29: Gun accessories for Insulation pins

Stud dimension	Chuck pos. 1	Foot plate pos. 2	Supporting tube pos. 3
from 3 x 35	350-0086-000 (steel) 350-0087-000 (copper)	370-0103-000	370-0167-000
from 4 x 35	350-0088-000 (steel)		
from 5 x 35	350-0089-000 (steel)		
Stud length up to (mm)	Required length of legs (mm)	Part-No. pos. 4	
Gun K 22			
140	240	370-0240-000	
200	300	370-0300-000	
300	400	370-0400-000	
400	500	370-0500-000	
500	600	370-0322-000	
600	700	370-0323-000	
Washer pos. 5		370-0055-000	
Screw with hexagon socket pos. 6		322-0372-000	

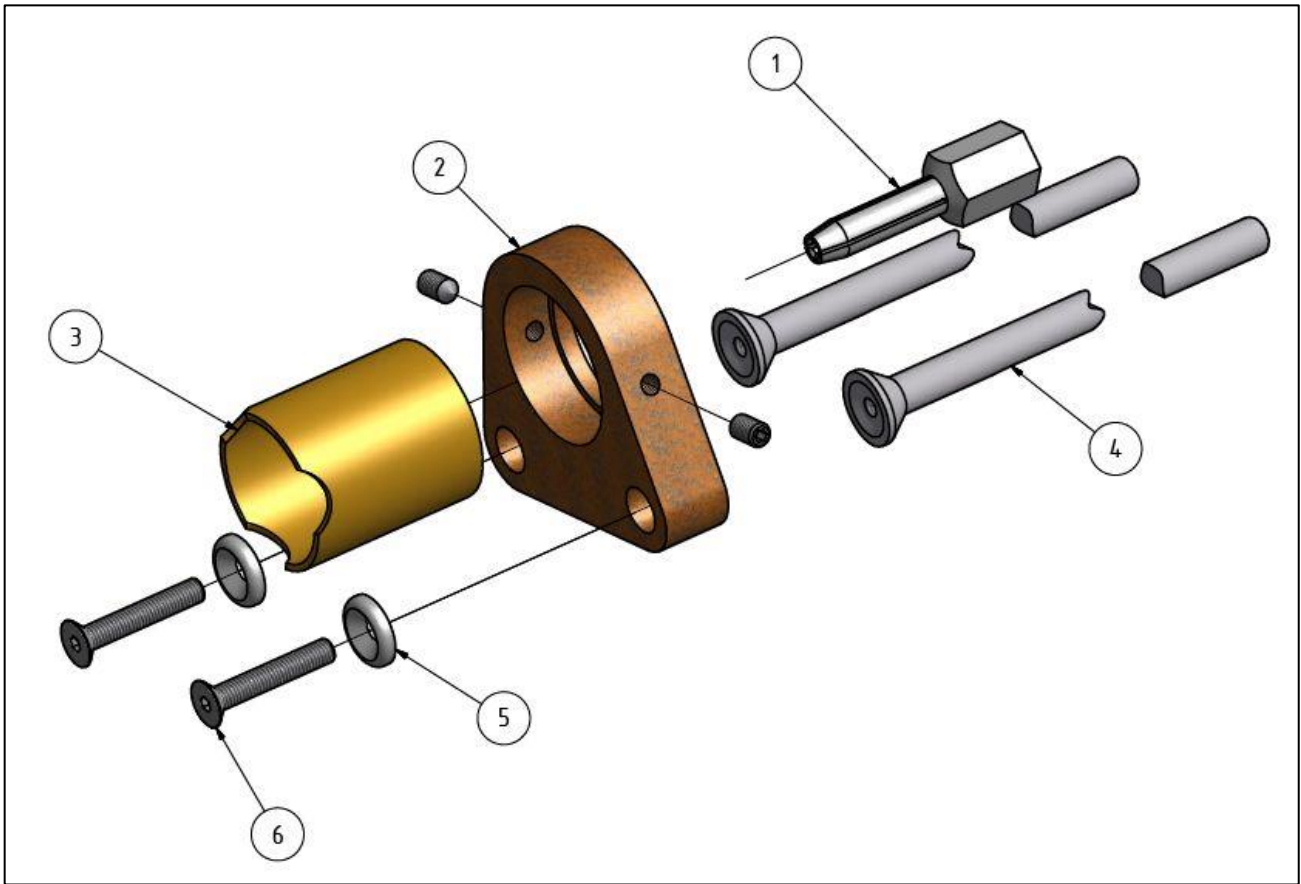

Figure 30: Gun accessories for short cycle stud welding without shielding gas

Stud diameter d	Chuck pos. 1	Foot plate pos. 2	Leg pos. 4	Supporting tube pos. 3
3	350-0001-000	360-0103-000	370-0240-000	370-0167-000
4	350-0002-000			
5	350-0003-000			
6	350-0005-000			
8	350-0007-000			
10	350-0009-000			
Washer pos. 5			370-0055-000	
Screw with hexagon socket pos. 6			322-0372-000	

For studs with lengths $L > \text{app. } 6d$ chucks with deeper grip length are recommended. Further information upon request.

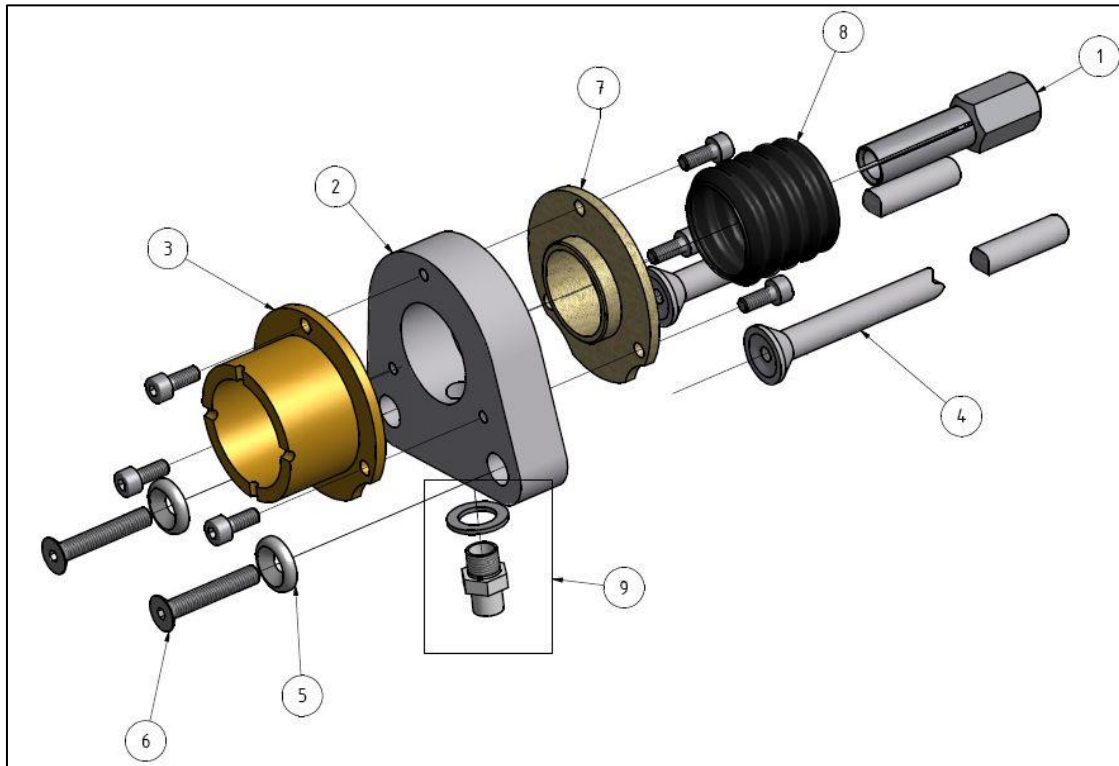

Figure 31: Gun accessories for stud welding with shielding gas

Stud diameter d	Chuck pos. 1	Foot plate with 3 socket head cap screws M 4 x 10 pos. 2	Leg pos. 4	Supporting tube with 3 socket head cap screws M 4 x 10 pos. 3
5	350-0003-000	322-0011-000	370-0240-000	322-0225-000
6	350-0005-000			
8	350-0007-000			
10	350-0009-000			
12	350-0011-000			
Washer pos. 5			370-0055-000	
Screw with hexagon socket pos. 6			322-0372-000	
Circlip ring with 3 socket head cap screw M 4 x 10 pos. 7			324-0042-000	
Bellows pos. 8			322-0098-000	
Gas plug with seal pos. 9			323-0017-000	
Set of shielding gas hoses, completely assembled, 7 m with clip-on connectors at both sides and 3 m with clip-on connector at one side, other side open (for hooking up to exit of pressure reducer)			323-6012-000	
See above, but 12 m and 3 m			323-6013-000	
Shielding gas equipment complete (pos. 2 to pos. 9)			324-6024-000	

Other lengths of shielding gas hoses upon request.

For studs with lengths $L > \text{app. } 6d$ chucks with deeper grip length are recommended. Further information upon request.

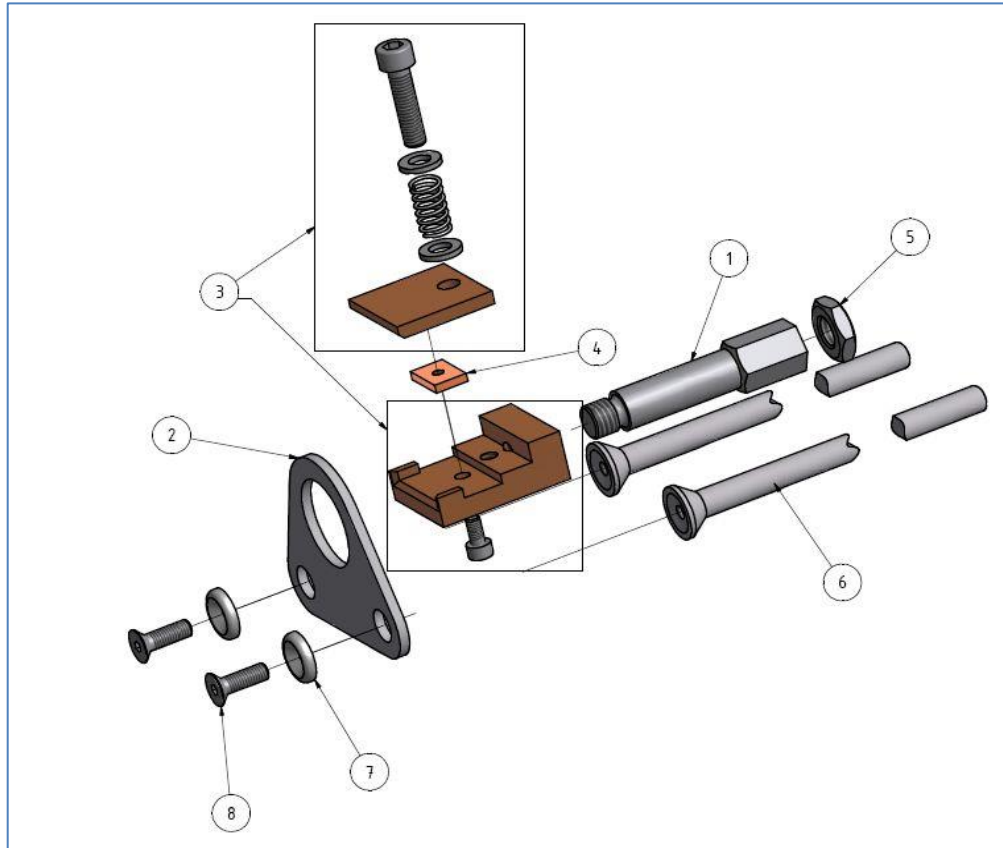

Figure 32: Gun accessories for flat anchors

W x T x L (Width x thickness x length)	Foot plate pos. 2	Chuck pos. 3	Stopping piece pos. 4
15 x 3 x > 25	360-0096-000	350-6045-000	350-0324-000
15 x 3 x > 35	360-0096-000	350-6045-000	-
20 x 3 x > 25	360-0088-000	350-6043-000	350-0324-000
20 x 3 x > 40	360-0088-000	350-6043-000	-
25 x 3 x > 25	360-0088-000	350-6044-000	350-0324-000
25 x 3 x > 40	360-0088-000	350-6043-000	-
15 x 5 x > 25	360-0096-000	350-6050-000	350-0225-000
15 x 5 x > 40	360-0096-000	350-6050-000	-
20 x 5 x > 25	360-0088-000	350-6049-000	350-0225-000
20 x 5 x > 40	360-0088-000	350-6050-000	-
25 x 5 x > 25	360-0088-000	350-6048-000	350-0225-000
25 x 5 x > 40	360-0088-000	350-6050-000	-
Chuck extension pos. 1		350-0075-000	
Leg pos. 6		370-0240-000	
Washer pos. 7		370-0055-000	
Screw with hexagon socket pos. 8		322-0379-000	
Counter nut pos. 9 (M 10 flat)		322-0378-000	

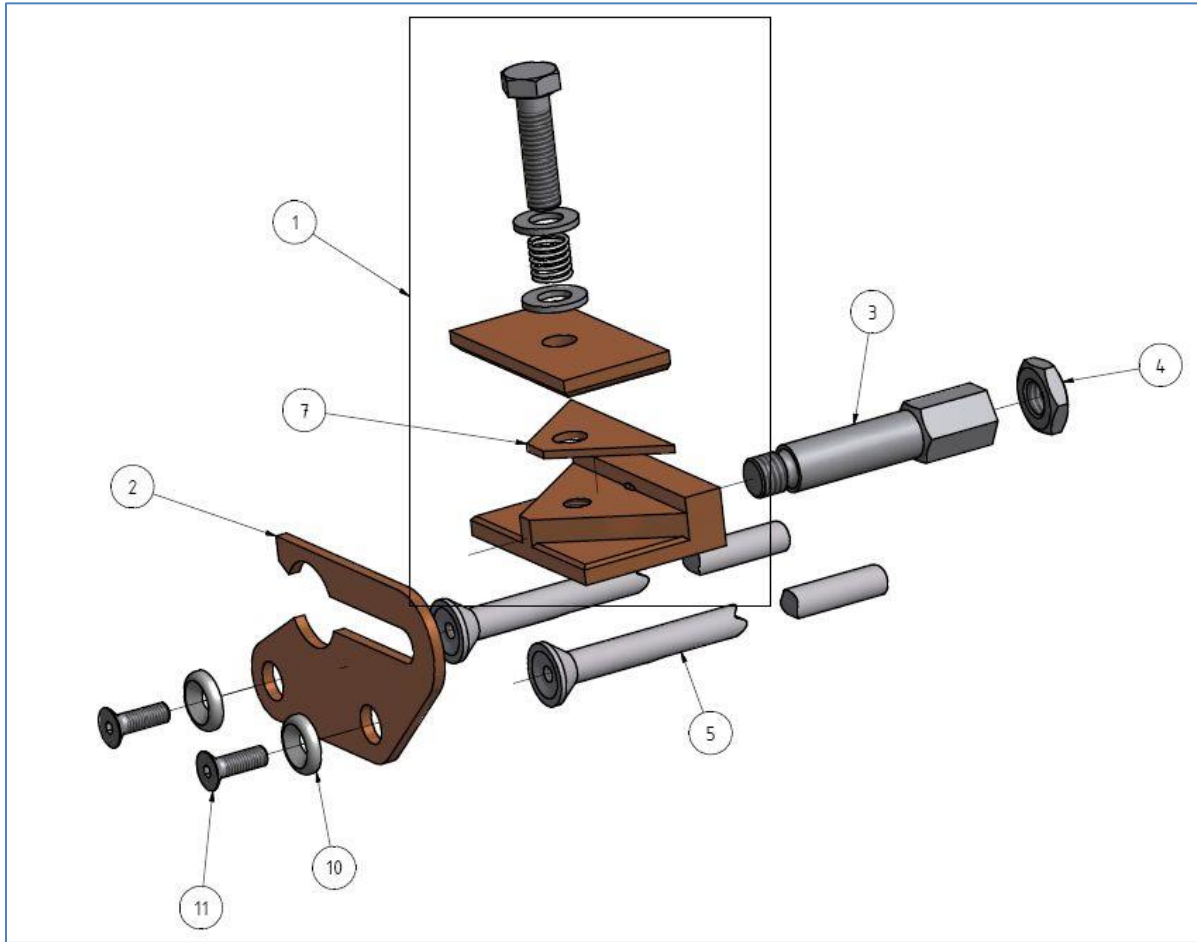

Figure 33: Gun accessories for Y-anchors

Dimension	Chuck pos. 1	Foot plate pos. 2	Chuck extension pos. 3	Counter nut pos. 4 (M 10 flat)	Compensation piece pos. 7
6 x 80°	350-6121-000	360-0122-000	350-0075-000	322-0378-000	-
8 x 80°		360-0123-000			350-0327-000
Leg pos. 5					
370-0240-000					
Washer pos. 10					
370-0055-000					
Screw with hexagon socket pos. 11					
322-0379-000					

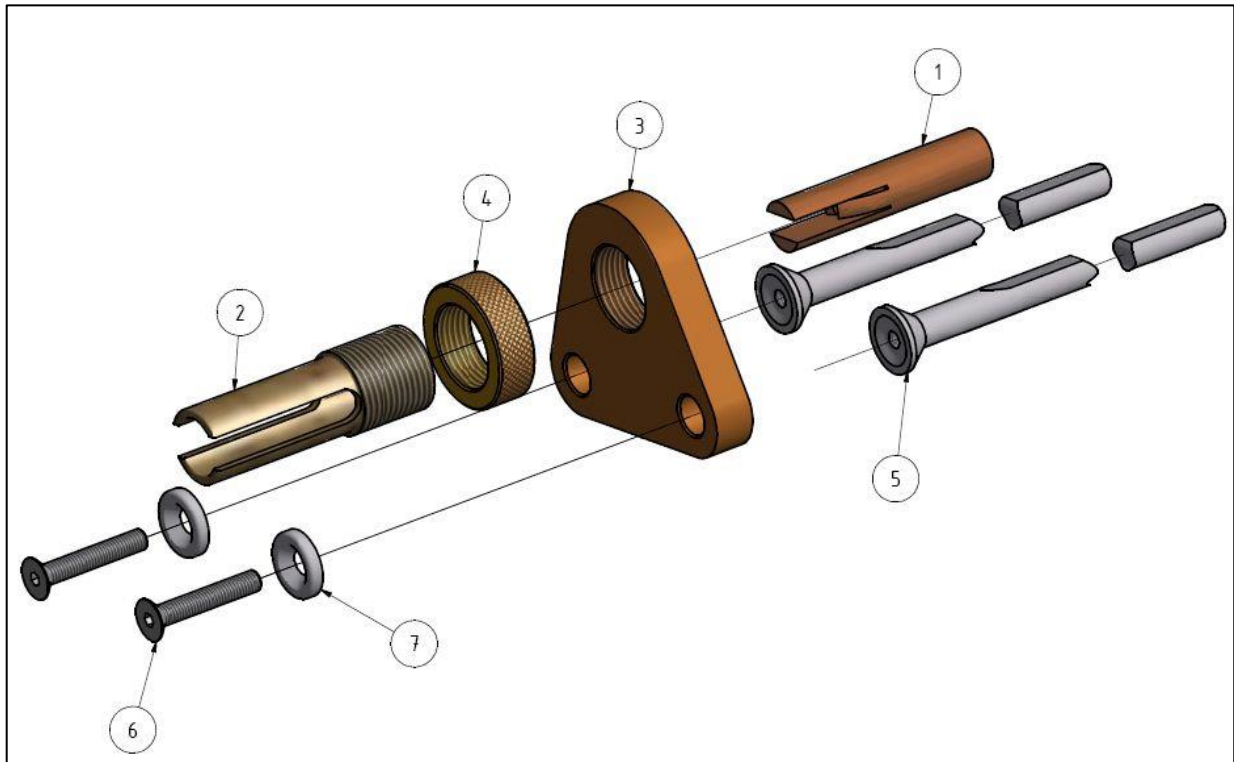

Figure 34: Gun accessories for reduced Y-anchors

Chuck pos. 1	Ferrule holder pos. 2	Foot plate pos. 3	Knurled nut pos. 4
350-0365-000	355-0272-000	360-0108-000	355-0250-000
Leg pos. 5	Screw with hexagon socket pos. 6	Washer pos. 7	
370-0240-000	322-0372-000	370-0055-000	

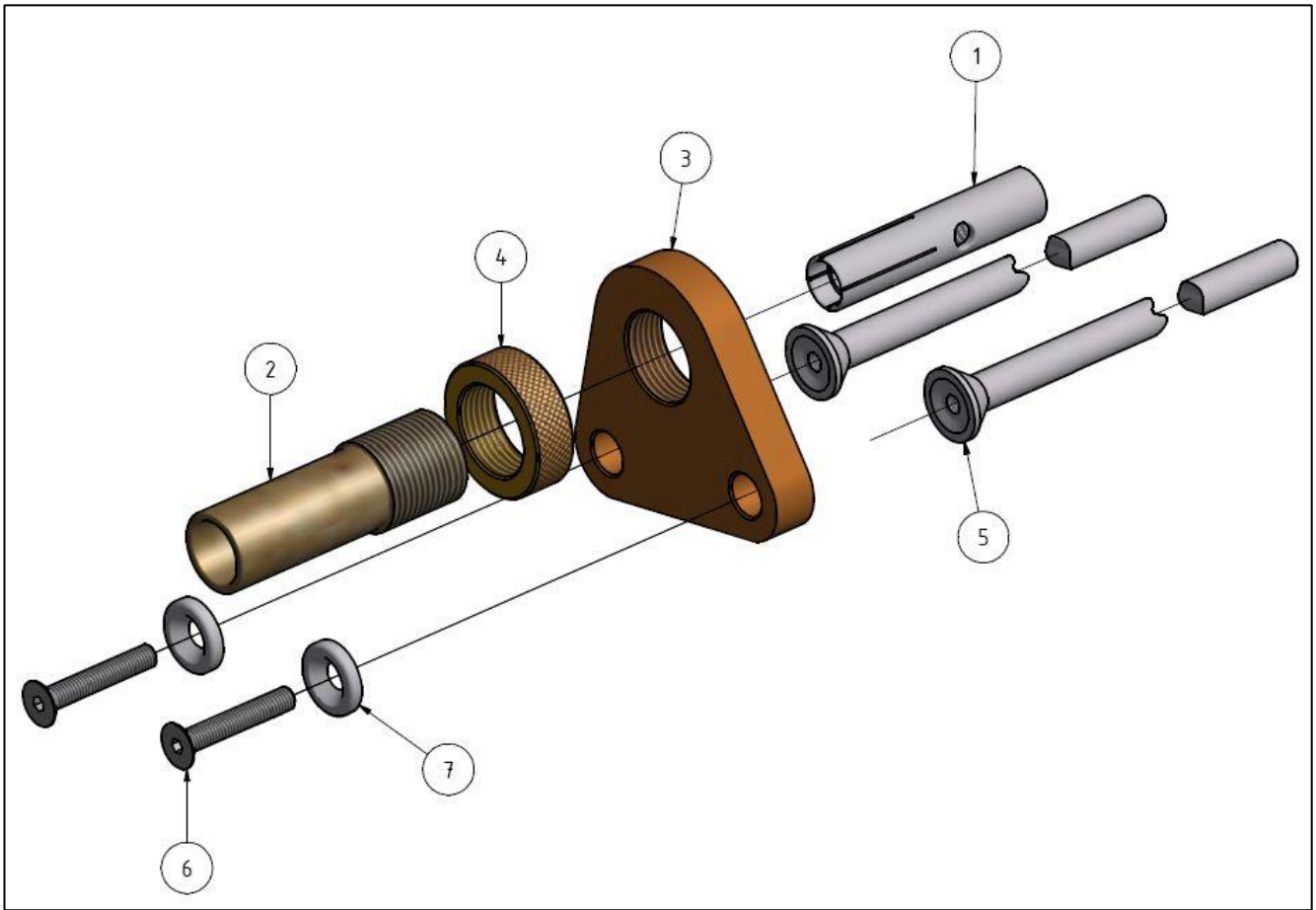

Figure 35: Gun accessories for boiler pins

Stud dimension	Chuck pos. 1	Ferrule holder pos. 2	Knurled nut pos. 3	Supporting tube pos. 4	Assembling plate pos. 5
6 x 14 - 20	350-0071-000	355-0151-000	355-0250-000	370-0173-000	322-0306-000
8 x 14 - 20	350-0072-000	355-0151-000			
10 x 14 - 20	350-0073-000	355-0152-000			
12 x 14 - 20	350-0074-000	355-0153-000			

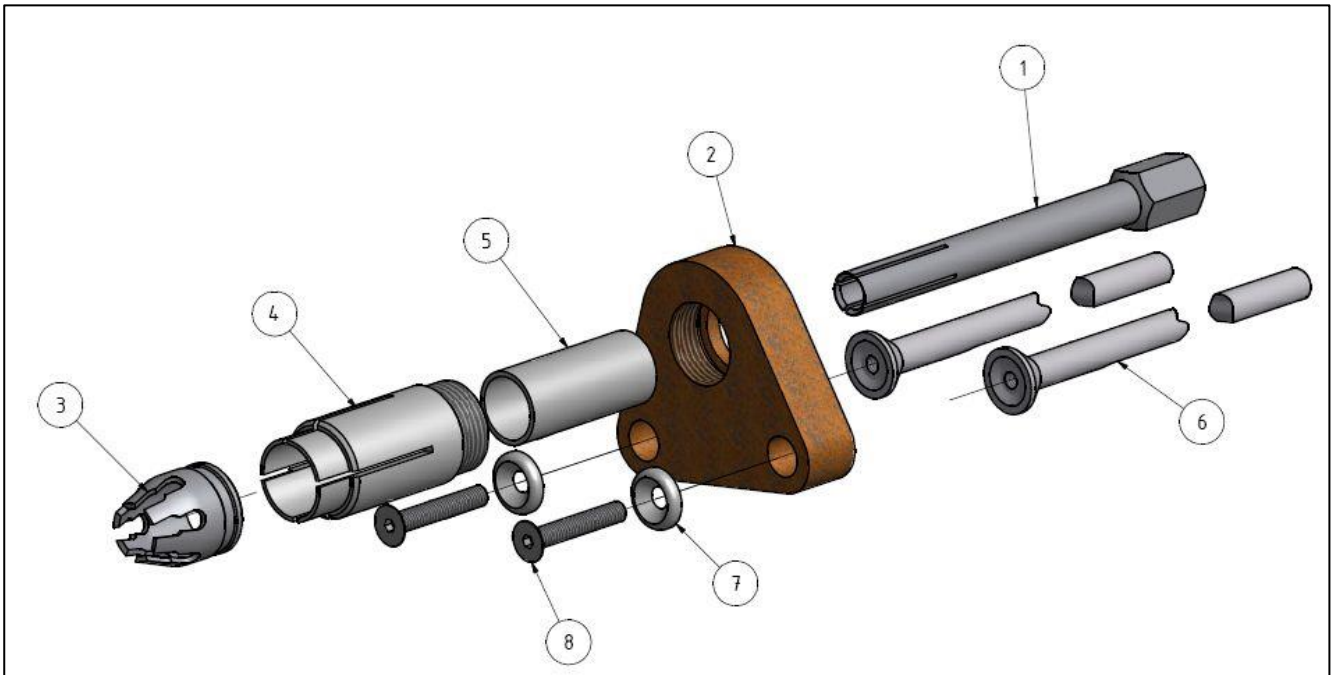

Figure 36: Gun accessories for grid fastening

Dimension	Chuck pos. 1	Ferrule grip pos. 3	Supporting tube pos. 4	Insulating tube pos. 5	Foot plate pos. 2
M 6 x > 20	350-0033-000	355-0002-000	370-0158-000	370-0159-000	360-0110-000
M 6 x > 60	350-0005-000				
M 8 x > 20	350-0034-000	355-0003-000			
M 8 x > 60	350-0007-000				
M 10 x > 25	350-0035-000	355-0004-000			
M 10 x > 60	350-0009-000				
M 12 x > 30	350-0036-000	355-0005-000			
M 12 x > 60	350-0011-000				
Washer pos. 7			370-0055-000		
Screw with hexagon socket pos. 8			322-0372-000		
Leg 240 mm pos. 6 (max. stud length 150 mm)			370-0240-000		

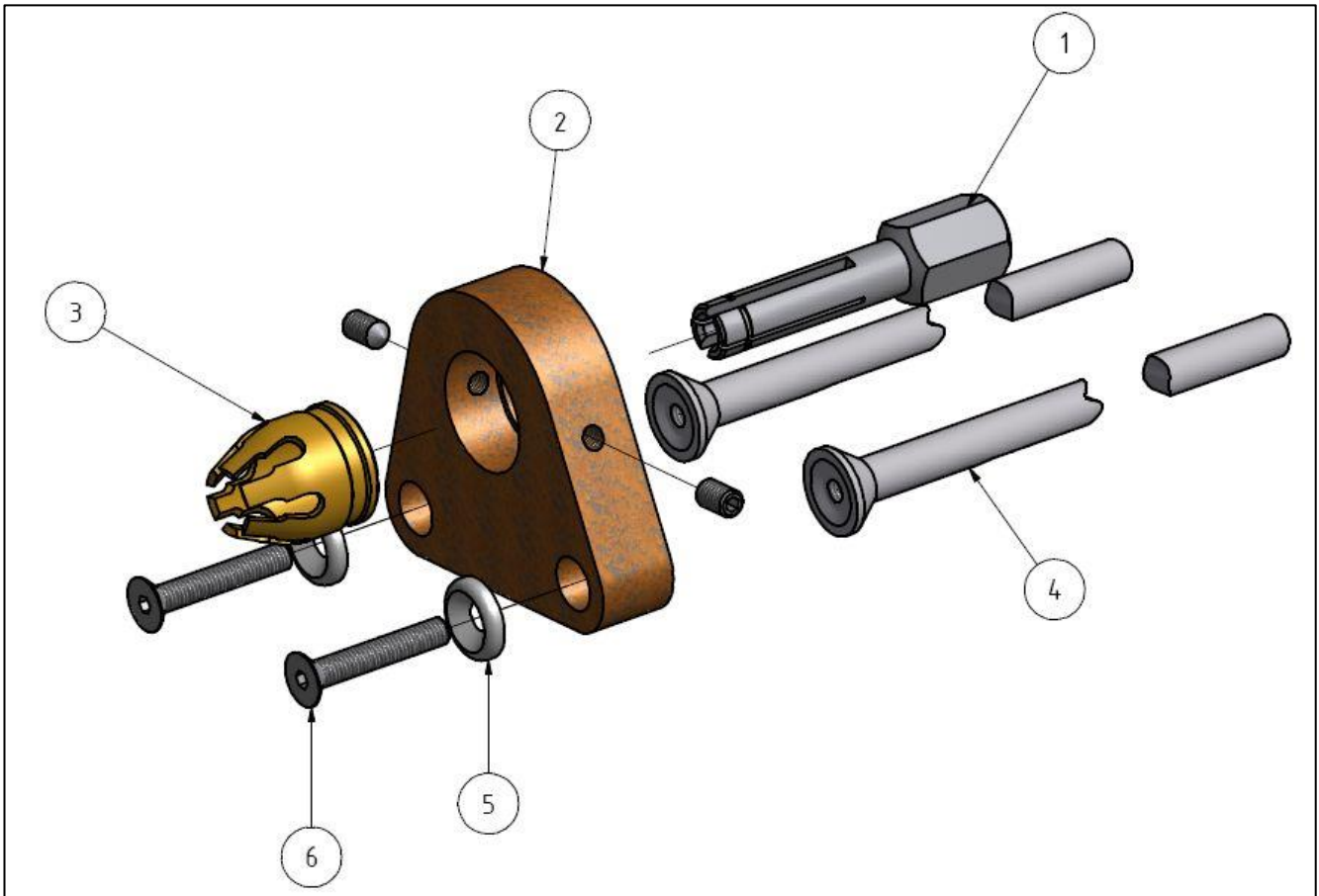

Figure 37: Gun accessories for welding of Fibrefix-pins Ø 5, Length L

Chuck pos. 1	Foot plate pos. 2	Ferule grip pos. 3	Leg pos. 4	
350-0100-000	360-0101-000	355-0002-000	370-0240-000 370-0300-000 370-0400-000 370-0500-000	up to L = 160 mm up to L = 220 mm up to L = 320 mm up to L = 420 mm
Washer pos. 5			370-0055-000	
Screw with hexagon socket pos. 6			322-0372-000	

12.2 Gun accessories for Gun series SK 14 and SK 15

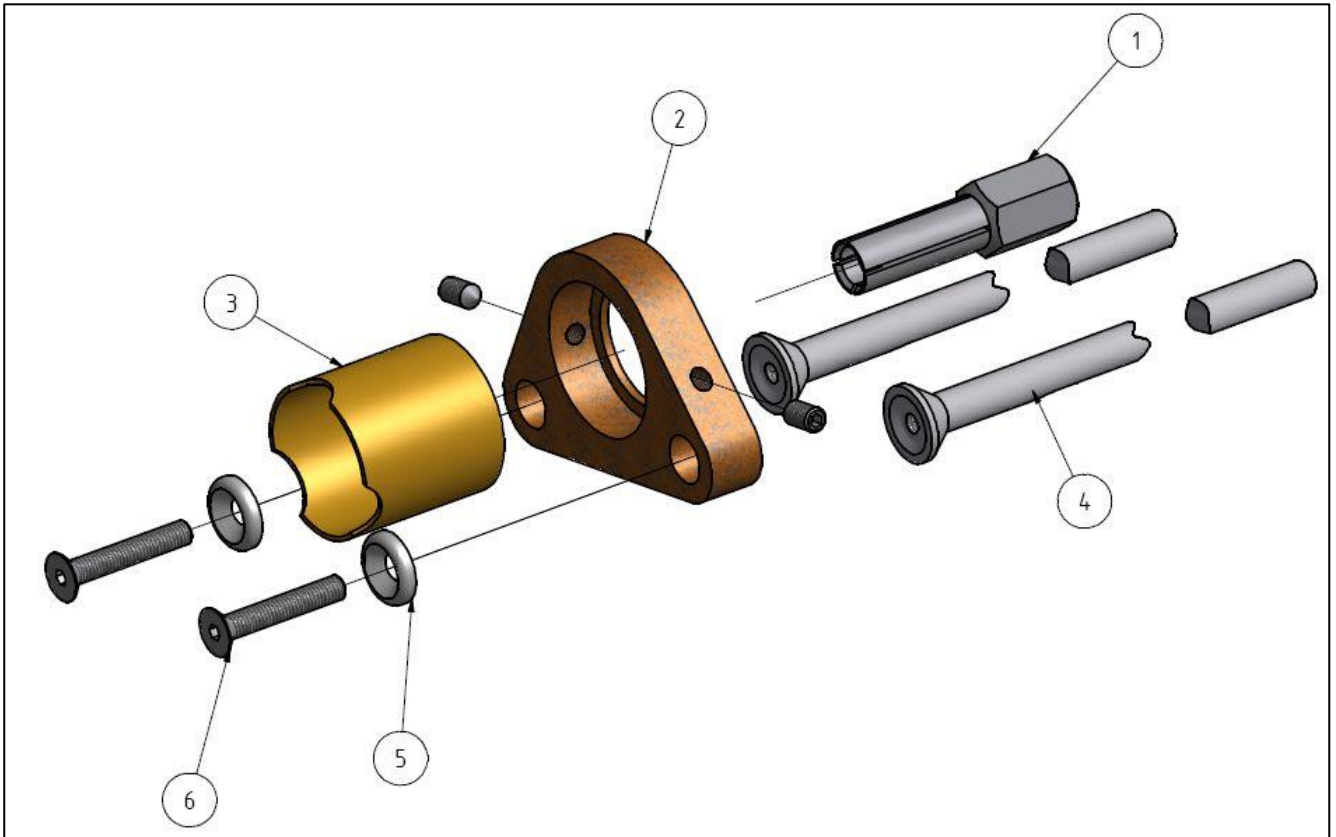

Figure 38: Gun accessories for short-cycle stud welding without shielding gas

Stud dimension (D x L)	Chuck pos. 1	Foot plate pos. 2	Leg pos. 4	Supporting tube pos. 3
Ø 3 x > 8	350-0001-000	360-0012-000	370-0240-000	360-0335-000
Ø 4 x > 8	350-0002-000			
Ø 5 x > 10	350-0003-000			
Ø 6 x > 10	350-0005-000			
Ø 8 x > 10	350-0006-000			
Ø 8 x > 15	350-0007-000			
Ø 10 x > 10	350-0008-000			
Ø 10 x > 15	350-0009-000			
Ø 12 x > 10	350-0010-000			
Ø 12 x > 16	350-0011-000			
Washer pos. 5		370-0055-000		
Screw with hexagon socket pos. 6		322-0372-000		

For studs with lengths $L > \text{app. } 6d$ chucks with deeper grip length are recommended. Further information upon request.

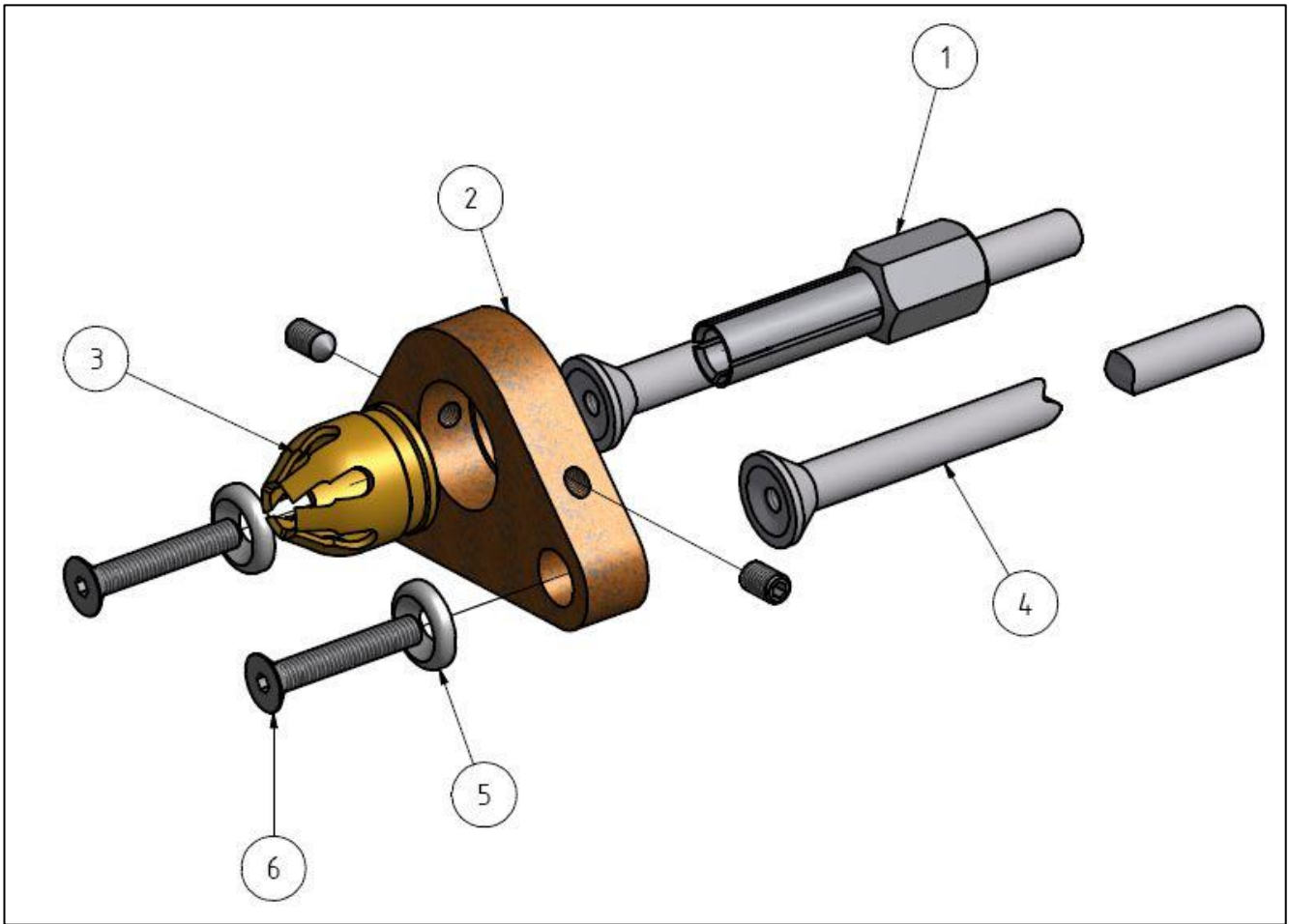

Figure 39: Gun accessories for threaded studs and plain pins

Type PD	Type DD	Type RD	Chuck pos. 1	Ferrule grip pos. 3	Foot plate pos. 2
M 4 x > 16	M 4 x > 16		350-0002-000	355-0001-000	360-0013-000
M 5 x > 16	M 5 x > 16		350-0003-000	355-0002-000	
M 6 x > 16	M 6 x > 16	M 6 x > 16	350-0004-000	355-0002-000	
M 6 x > 20	M 6 x > 20	M 6 x > 20	350-0005-000	355-0002-000	
M 8 x > 16	M 8 x > 16	M 8 x > 16	350-0006-000	355-0003-000	
M 8 x > 20	M 8 x > 20	M 8 x > 20	350-0007-000	355-0003-000	
M 10 x > 16	M 10 x > 20	M 10 x > 20	350-0008-000	355-0004-000	
M 10 x > 20	M 10 x > 25	M 10 x > 25	350-0009-000	355-0004-000	
M 12 x > 16	M 12 x > 20	M 12 x > 20	350-0010-000	355-0005-000	
M 12 x > 25	M 12 x > 25	M 12 x > 30	350-0011-000	355-0005-000	
Leg pos. 4		370-0240-000			
Washer pos. 5		370-0055-000			
Screw with hexagon socket pos. 6		322-0372-000			

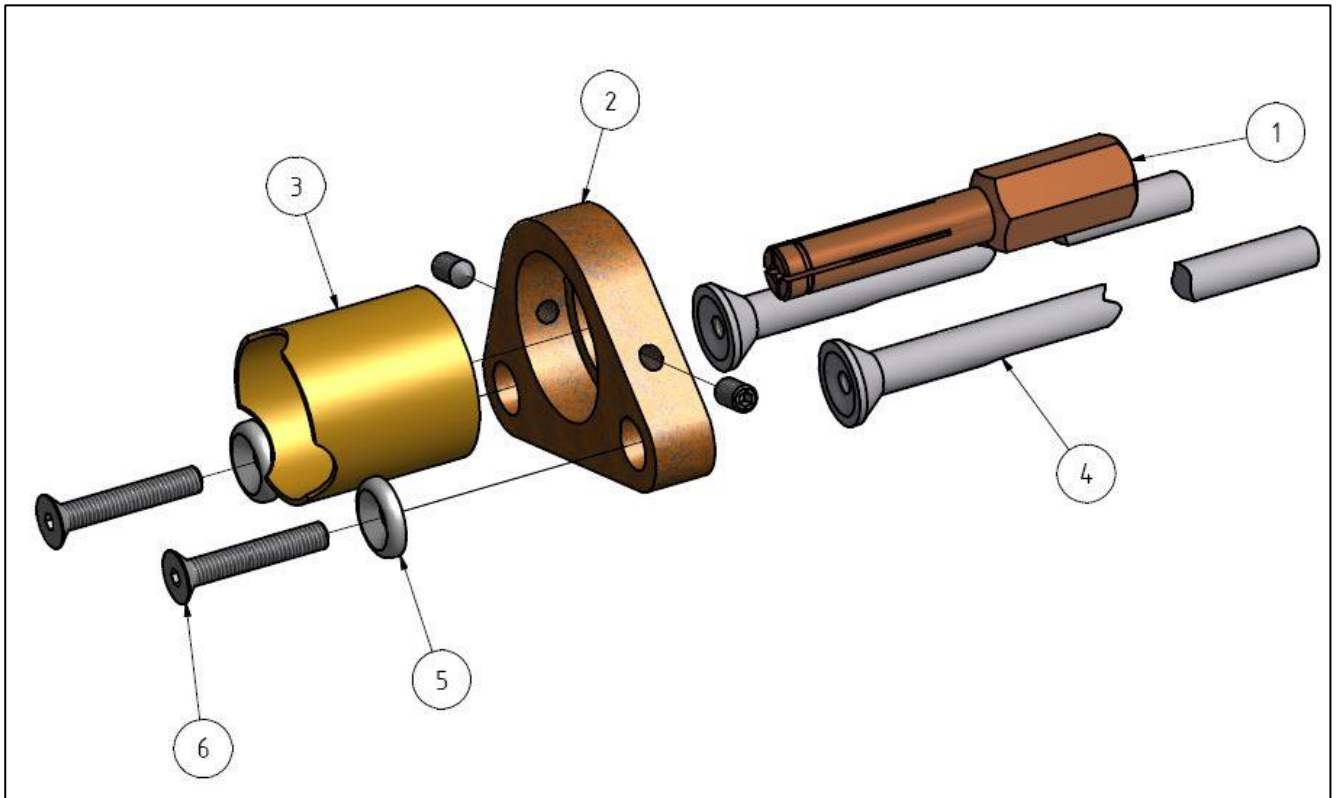

Figure 40: Gun accessories for insulation pins

Stud dimension	Chuck pos. 1	Foot plate pos. 2	Supporting tube pos. 3
from 3 x 35	350-0086-000 (Steel) 350-0087-000 (Copper)	360-0012-000	360-0335-000
from 4 x 35	350-0088-000 (Steel)		
from 5 x 35	350-0089-000 (Steel)		
Stud length up to (mm)	Required length of legs (mm)	Leg pos. 4	
140	240	370-0240-000	
200	300	370-0300-000	
300	400	370-0400-000	
400	500	370-0500-000	
500	600	370-0322-000	
600	700	370-0323-000	
Washer pos. 5		370-0055-000	
Screw with hexagon socket pos. 6		322-0372-000	

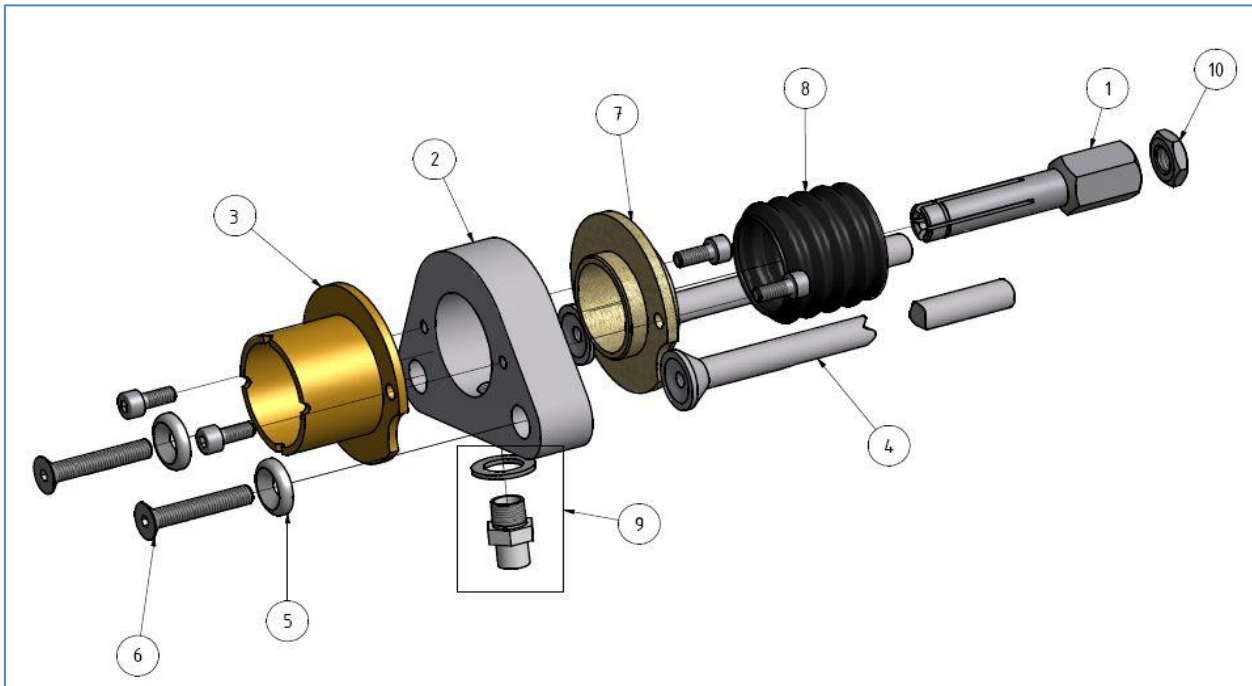

Figure 41: Gun accessories for stud welding with shielding gas

Stud diameter d	Chuck pos. 1	Foot plate with 2 socket head cap screws M 4 x 10 pos. 2	Leg pos. 4	Supporting tube with 2 socket head cap screws M 4 x 10 pos. 3
5	350-0003-000	324-0048-000	370-0240-000	324-0049-000
6	350-0005-000			
8	350-0007-000			
10	350-0009-000			
12	350-0011-000			
Washer pos. 5			370-0055-000	
Screw with hexagon socket pos. 6			322-0372-000	
Circlip ring with 2 socket head cap screws M 4 x 10 pos. 7			324-0047-000	
Bellows pos. 8			322-0098-000	
Gas plug with seal pos. 9			323-0017-000	
Counter nut pos. 10 (M 10 flat) (required for stud length < 16 mm)			322-0378-000	
Set of shielding gas hoses, completely assembled, 5 m with clip-on connectors at both sides and 3 m with clip-on connector at one side, other side open (for hooking up to exit of pressure reducer)			323-6011-000	
Shielding gas equipment complete (Pos. 2 to Pos. 9)			324-6025-000	

Other lengths of shielding gas hoses upon request. For studs with lengths $L > \text{app. } 6d$ chucks with deeper grip length are recommended. Further information upon request.

13 Literature

EN ISO 14555 "Drawn arc stud welding of metallic materials"

EN ISO 13918 "Studs and Ceramic Ferrules for Drawn Arc Stud Welding"

DVS-Technical Bulletin 0901 "Stud Welding Procedures for Metals – Overview"

DVS-Technical Bulletin 0902 "Drawn Arc Stud Welding"

DVS-Technical Bulletin 0903 "Stud Welding with Tip Ignition"

DVS-Technical Bulletin 0904 "Drawn Arc Stud Welding – Practical hints"

Trillmich, R. and Welz, W.: "Stud Welding – Principles and Applications", DVS-Media, english edition, vol. 12, Düsseldorf 2016